



# Coffee Crafters



## Valenta 18

### 18-lb. Commercial Fluid Bed Coffee Roaster Manual

708 S. Clearwater Loop Ste 105  
Post Falls, ID 83854

[www.coffeecrafters.com](http://www.coffeecrafters.com)

Phone (509)228-6916

[info@coffeecrafters.com](mailto:info@coffeecrafters.com)

Copyright © 2024 Coffee Crafters LLC All Rights Reserved

# Contents

Introduction .....	4
About Us .....	4
Our Mission .....	4
Our Vision .....	4
Valenta 18 Model Complete Roasting & Bean Cooling System Specifications .....	5
Warranty And Guarantee.....	6
Valenta 18 Model Warranty .....	6
What Is Not Covered by The Warranty.....	6
Assembly And Installation.....	8
Assembly Introduction.....	8
Hardware Packages .....	8
Taking Roaster Off the Pallet.....	10
Installing Hood.....	11
Thermometer .....	12
Mounting the Thermometer Bracket to Roaster .....	13
Attaching Probe .....	14
Attaching Loading Chute .....	15
Installing Power Distribution Block and Tube .....	16
Assembling the Cyclone.....	17
Assembling the Bean Cooler.....	18
Installing Exhaust Blower.....	19
Installing Ducting .....	20
Ventilation installation .....	22
Light Kit Installation .....	23
Temperature Switch .....	24
Helpful Tips.....	25
Roasting .....	26
Roast Coffee In 7 Easy Steps.....	26
Check Chaff Bag .....	26
Turn On Exhaust Blower .....	26
Turn On System Power Switch.....	27
Set Bean Loft.....	28

Load Beans in Top Green Bean Hopper .....	29
Turn on Heating Element.....	30
Roasting Complete: Cool the Beans.....	31-32
Coffee Bean Education .....	33
Proper Storage of Green Coffee Beans.....	33
Green Coffee Bean Abbreviations and Meanings.....	34
Maintenance And Troubleshooting.....	35
Maintenance.....	35
Chaff Bags .....	35
Roast Hopper Cleaning .....	35
Bean Cooling Tray .....	35
Exhaust Tubing .....	36
Exterior Surfaces.....	36
Troubleshooting .....	37-44
Exhaust Blower Losing Suction.....	37
Bean Loft Motor Won't Run .....	38
Both Heat Elements Won't Turn On.....	39
Bean Loft Motor Runs at Full Speed Only.....	39
Both Elements Running but Roasts Take Too Long .....	40
Air Coming Out of Dump Gate .....	40
Troubleshooting Figure 1.1 .....	41
Troubleshooting Figure 1.3 .....	42
Troubleshooting Figure 1.4 – SSR Connections.....	43
Troubleshooting Figure 1.5 – Contactors.....	44
Wiring Diagram USA.....	45
Wiring Diagram EUR .....	46
Part List.....	47

# Introduction

In this manual, you will find everything needed to start roasting coffee. Included in this copy is a description of your warranty/guarantee, detailed information on installation and assembly, roasting instructions, additional information on green beans, and a troubleshooting guide.

## About Us

While living in Thailand and unable to find fresh roasted coffee, Ken Lathrop, developer of Coffee Crafter's Valenta 18 coffee roaster, conceived of a concept to design and build a reliable, affordable machine capable of roasting five pounds or more of coffee beans in less than ten minutes.

"My goal was to enable new roasters – to help them roast their own beans and have fun doing it", says Lathrop. "My focus was to design and build a roaster that could be easy for anyone to learn and use, a roaster that could roast five pounds or more per roast batch and was easily installed and affordable for anyone. From the response we have received from customers and at coffee shows, I think we succeeded."

Coffee Crafters designed and began selling its Artisan V fluid bed coffee roaster in August 2013. "We built the Artisan roaster specifically to serve small roasters or those new to the industry", says Lathrop. "The installation is similar to your home clothes dryer – very simple and straightforward. After installation we find that our customers are up to speed and roasting typically within 30 minutes."

## Our Mission

To become the best and largest supplier of high-quality affordable coffee "micro-roasting" equipment in the world.

### **"Micro-Roasting" defined:**

1. Hands on craft roasted coffee
2. Roasting 100 lbs. or less per day
3. Supply "fresh" coffee to customers immediately after roasting at its peak of freshness

## Our Vision

We will maintain an uncompromising commitment to our "micro-roasting" customers by:

- Serving our customers the way we would like to be taken care of.
- Providing our customers with equipment, supplies and information to satisfy all of their micro-roasting needs.
- Supplying high quality products engineered and manufactured in the USA.
- Delivering affordable equipment factory direct.



## Valenta 18 Coffee Roaster

Energy Efficient Fluid Bed  
Coffee Roasting System

### Valenta 18 Complete Roasting & Bean Cooling System Specifications

Roaster Production	Varies based on batch size and roast time
Roast Time	9-12 minutes
Chaff Collection	Stand-alone chaff cyclone system
Bean Cooling	External 18 lbs. capacity
Roast Air Temperature	Variable manual control Fahrenheit or Celsius
Bean Temperature Thermometer	Included
Roaster Power	Single-phase 100-amps, 240v
Exhaust Blower System Power	Single-phase 20-amp, 230V 60 Hz
Roaster Heat	15,600 watts
Batch Size	2 lbs to 18 lbs
Venting	Rigid ducting required, not included
Minimum Floor Space for full system	7' wide by 7' long

### Dimensions & Weight

Roaster	68.2" tall x 19.1" long x 56.2" wide
Cyclone	62.4" tall x 20" wide
Exhaust Blower 1550 CFM	16.25" wide x 19" deep x 19.75" tall
Shipping Weight	465 lbs.
Shipping Dimensions	1 Pallet (40x48x68 inches)

### Electricity Usage

Full 18 lb. load	0.4 kWh per pound
Min 2 lbs load	1.0 kWh per pound

### Certification

UL

CE

Coffee Crafters  
708 S Clearwater Loop, Suite 105, Post Falls, ID 83854  
(509)228-6916 – [sales@coffeecrafters.com](mailto:sales@coffeecrafters.com)

# Warranty and Guarantee

## Valenta 18 Model Warranty

Your Valenta 18 Roaster has been manufactured and tested to the highest quality standards by Coffee Crafters. This Limited Warranty covers defects in material or workmanship on new Valenta roasters. The Warranty extends to the original purchaser only and is non-transferable. Only consumers purchasing roasters from Coffee Crafters may obtain coverage under our limited warranty.

Coffee Crafters warrants this product against defects in material or workmanship as follows:

- Under normal installation per Coffee Crafters instructions, use, service, and maintenance for a period of one year from the original purchase date, Coffee Crafters will replace at no charge, any product or part of the product that proves defective because of improper workmanship and/or material.

The specific warranties expressed are the ONLY warranties provided by the manufacturer. These warranties give you specific legal rights, and you may also have other rights which vary from state to state.

## What is Not Covered by the Warranty

1. Conditions and damages resulting from any of the following:
  - a. Improper installation, delivery, or maintenance.
  - b. Any repair, modification, alteration, or adjustment not authorized by the manufacturer.
  - c. Misuse, abuse, accidents, unreasonable use, or acts of God.
  - d. Incorrect electric current, voltage.
  - e. Improper setting of any control.
  - f. Use of risers (pedestals) that are not authorized by the manufacturer.
  - g. The Warranty is void if a product is returned with removed, damaged, or tampered labels or equipment, or any alterations.
2. The Warranty is void if the original serial numbers have been removed, altered, or cannot be readily determined.
3. Products purchased for use other than roasting coffee.
4. Any food loss due to product failures.
5. Expenses for travel and transportation for product service.
6. Consequential or incidental damages sustained by any person as a result of any breach of these warranties. Some states do not allow the exclusion or limitation of consequential or incidental damages, so the above exclusion may not apply.

## If You Need Service

1. See the Maintenance/Troubleshooting section of this manual.
2. Visit our YouTube channel to find Maintenance and Troubleshooting videos for tips on fixing/replacing roaster parts
3. If you are still having issues with the roaster, give us a call or send us an email so we can figure out the problem with you.
  - Phone: 509-228-6916
  - Email: [info@coffeecrafters.com](mailto:info@coffeecrafters.com)

## 30-Day Complete Satisfaction & Money-Back Guarantee

We want you to be fully satisfied with every item that you purchase from Coffee Crafters. If you are not satisfied with an item that you have purchased, you may return the item within 30 days of purchase date for a full refund of the purchase price, minus the shipping, handling, or other additional charges.

## Return Instructions

Please note: For the purposes of tracking and insurance, all returns must be shipped to Coffee Crafters.

1. Pack the item securely in the original package, if possible. Enclose the return portion of the original packing slip with the item.
2. All products must be returned in excellent condition, in original boxes, and with all paperwork, parts and accessories to ensure full credit.
3. All return shipping charges must be prepaid. We cannot accept C.O.D. deliveries.
4. Keep the Return Tracking Number from the package you are returning to ensure that the package is returned to the warehouse.
5. You can expect a refund in the same form of payment originally used for purchase usually within 10-15 business days of our receiving your returned product. Returned funds may reflect charges for incomplete components or damage materials. Delays may be experienced in the case of incomplete returns. Please note that your shipping costs will not be refunded.

## Receipt of Damaged or Defective Items

If you receive a damaged or defective item, contact Coffee Crafters Customer Service Department at 1-509-228-6916 immediately upon receiving the item. Please supply your order number, item number and tracking number from your original confirmation e-mail. Coffee Crafters will also need your e-mail address and phone number.

A defective item may be repaired or replaced within 30 days of purchase under Coffee Crafters Warranty.

# Assembly and Installation

## Assembly Introduction

Your Valenta 18 roaster comes mostly assembled. The following instructions will help you complete the assembly process correctly.

Before you start the assembly process you must select a suitable location for the Roaster and Blower System. The customer must supply all rigid ducting for the venting except for the fittings provided by Coffee Crafters (see page 20 for more details). Make sure to check with local codes for venting requirements as noted in the ventilation installation section of this manual. When correctly installed, the exhaust gas temperature will not exceed 170° Fahrenheit.

The Roaster must be positioned on a flat smooth surface, do not install on carpet. Make sure the Roaster has at least a 6-inch gap between the back vent pipes and the wall.

## Hardware Packages

Your Valenta 18 roaster comes with all the fittings and hardware needed to assemble the roaster. Not included is the electrical cord or ducting. A complete list of included hardware and fittings and listed below.

**Please Note: ALL HARDWARE is labelled by part and located in the bean cooler tray in bags.**

### Bean Cooler Exhaust:

- 4 – 8/32 Keps Nuts
- 20” piece of high heat tape

### Bean Cooler Handle:

- 4 – ¼-20x3/4 SS Bolts
- 4 – ¼ Lock Washer
- 4 – ¼-20 Nuts

### Distribution Box & Tube:

- 2 – 8/32 Screws for box
- 2 – 8/32 Screws for Tube

### Cyclone Top:

- 18 – ¼-20 Flat Washers
- 18 – ¼-20 Bolts

### Thermometer & Hood:

- 3 – 8/32 Screws for Thermometer
- 1 – 8/32 Screw for Hood

### Duct Fittings:

- 6x6x6 Wye
- 6-inch, 90-degree rigid duct
- 6- to 5-inch reducer
- 5-inch crimp duct

# ASSEMBLING YOUR VALENTA 18 ROASTER



## ACCESSORY KIT



- Manual and Roast Log
- Gooseneck Lamp in box
- Thermometer Kit in blue case
- 2 roast Chamber Gaskets (extras)
- Roast Chamber Release Handle
- Hood/Loading Chute
- Bean Cooler Exhaust Fitting
- Bean Cooler Handles x2
- Power Distribution Box and Tube
- Hermetheus Co-Pilot Manual and USB

## Taking the Roaster Off of the Pallet

Step 1: Unscrew the Shipping Brackets on the front and back of the roaster. You can throw out the Shipping Brackets and the zinc screws, they are no longer needed.

Step 2: Take the roaster off of the pallet and place it in your roasting area.

Step 3: Screw the four provided black screws back into the holes the zinc screws holding the shipping brackets came out of on the front and back of the roaster as pictured below.

FRONT

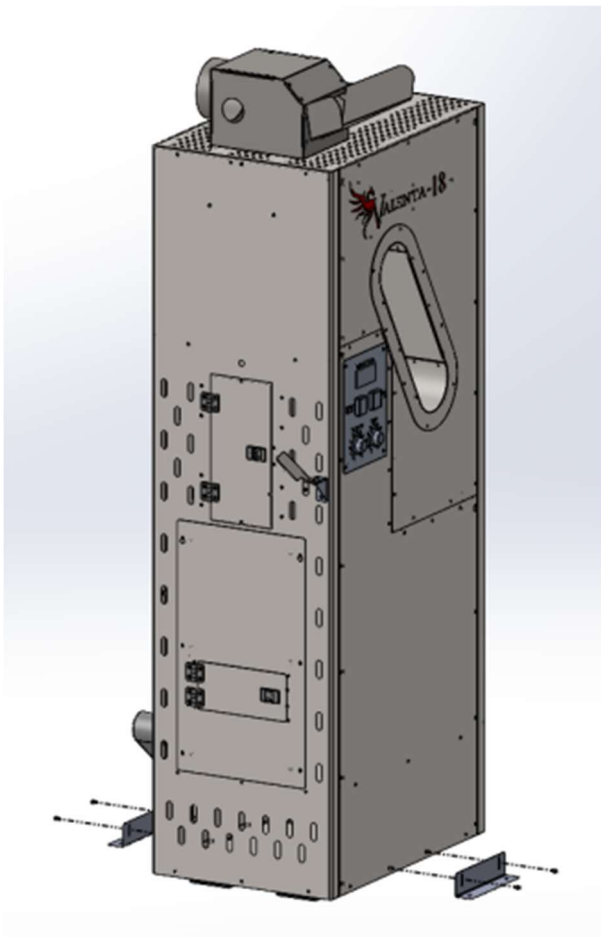

BACK

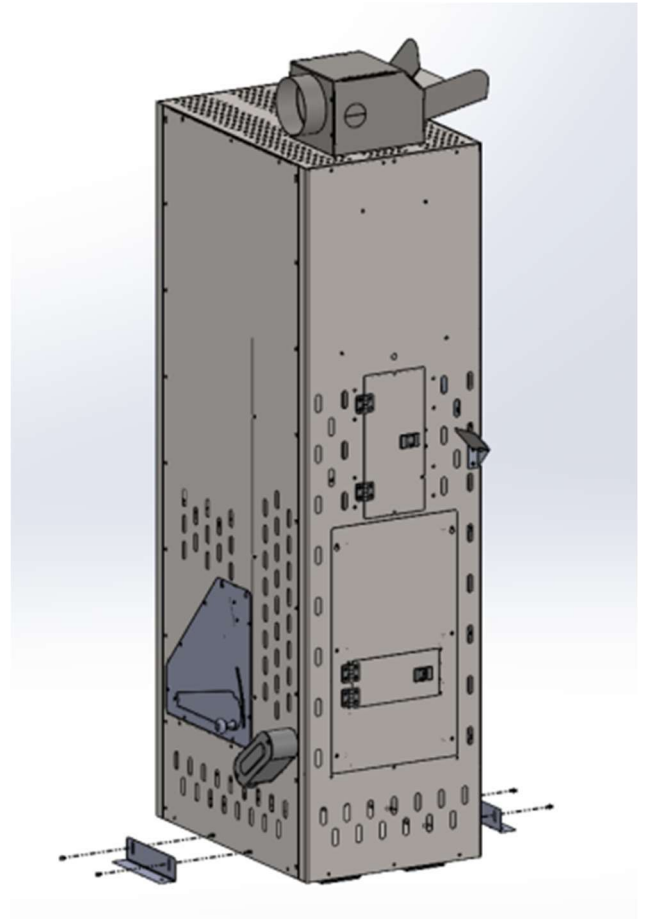

## VALENTA 18 HOOD INSTALLATION

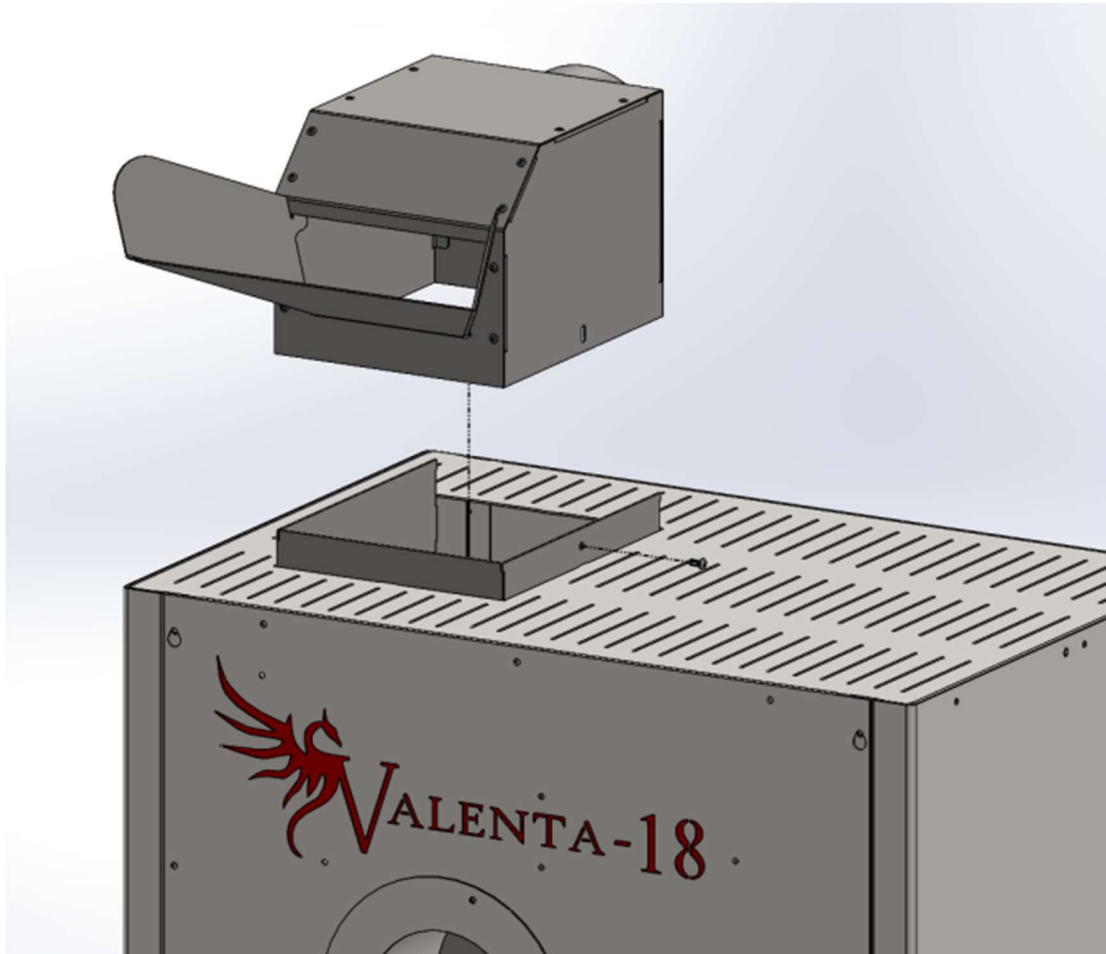

Slide the hood over the top of the roaster as pictured above. Secure the hood with the provided 8/32 screw and tighten down.

## Thermometer

Your thermometer will be placed on the Thermometer bracket located on the left side of the roaster (see next page for instructions).

The Digi-Sense Thermometer is very easy to operate (pictured). The large display makes the bean temperature reading easy to see. There are only a few basic operating functions.

1. The meter has an auto off function and will power down after 30 minutes with no key operation. To disable the auto power off mode, press and hold the “H” and “Power” keys at the same time. The clock dial in the upper left corner of the screen will disappear and the auto off will be disabled.
2. When the battery voltage is under the proper operation requirements the low battery symbol will show on the LCD screen and the battery will need to be replaced.



The thermometer comes to you with the battery and thermocouple probe installed and tested. Velcro has been applied to the back of the thermometer. To install it on the thermometer bracket, remove the plastic from the Velcro and install it on the bracket as shown in the pictures on the next page. The bottom of the thermometer should be even with the bottom of the thermometer bracket.

## Mounting the Thermometer Bracket to Roaster

**Step 1:** Attach bracket base to the two the protruding studs on the left side of the roaster. Tighten with two 8/32 screws. Use the other 8/32 screw to attach bracket to the base.

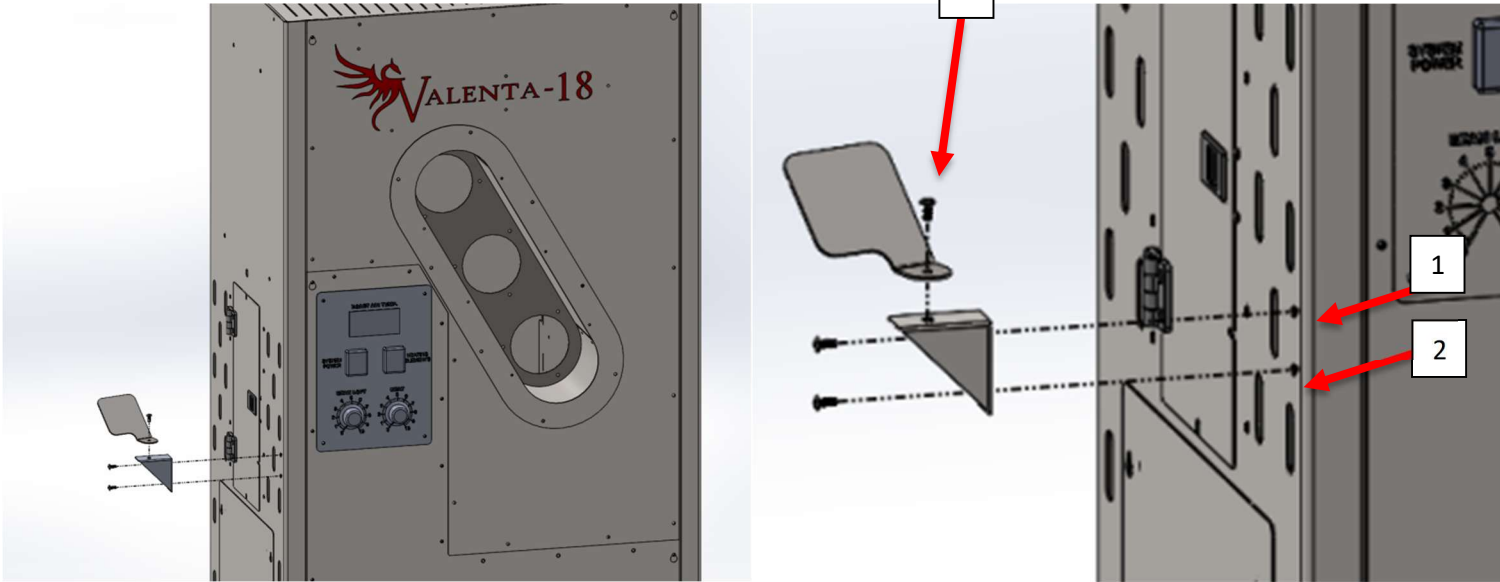

**Step 2:** Peel the sticker off the back of the thermometer Velcro strips.



**Step 3:** Secure thermometer to thermometer bracket and press firmly.

## Attaching the Thermocouple Probe

**Step 1:** Bring wire behind thermometer and plug into bottom of thermometer being careful to insert it into the correct slots. You will not get any readings from the probe if the wire is installed backwards.



## Attaching the Loading Chute

Place the Loading Chute into the opening of the Hood as pictured below. The Loading Chute will latch onto the Hood and should stay securely. There is no need to attach the chute with hardware or tape.



## INSTALLING THE POWER DISTRIBUTION BLOCK AND TUBE

1. Remove the panel that covers the electrical assembly on the left side of the roaster as shown below.
2. Take off the front plate on the power distribution box in order to access the inside of the box. Use two of the 8/32 screws provided to secure the box to the back of the roaster as shown below. You can leave the front plate off for now as it will need to be off for your electrician to run the wires.
3. Use the two remaining 8/32 screws to secure the tube to the roaster from the inside, below the electrical assembly as shown below. Please note, the tube should secure to the hole on the box, the screws will not fit otherwise.

**Note:** We recommend having an electrician wire the roaster for you based on your building's electrical setup.

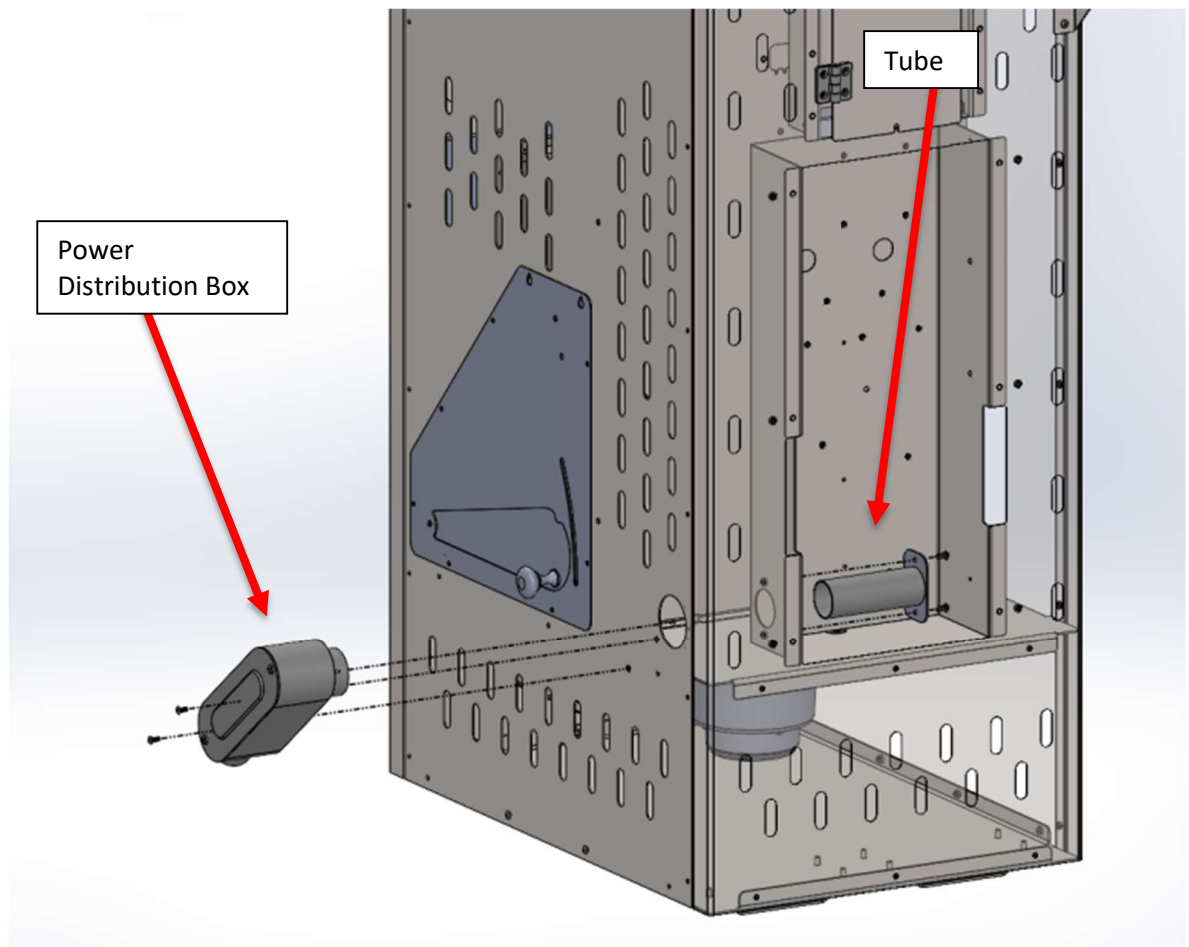

## ASSEMBLING THE CYCLONE

1. The Cyclone arrives upside down on the same pallet as the roaster. Take the Cyclone off the pallet and turn it right side up.
2. Remove the two Cyclone Top pieces from the box and grab the cyclone hardware kit located in the accessory kit.
3. Use six of the  $\frac{1}{4}$ -20 bolts and flat washers to secure the Cyclone Top pieces together as shown in the picture.
4. Use the remaining hardware to secure the Cyclone Top to the Cyclone as shown in the picture.

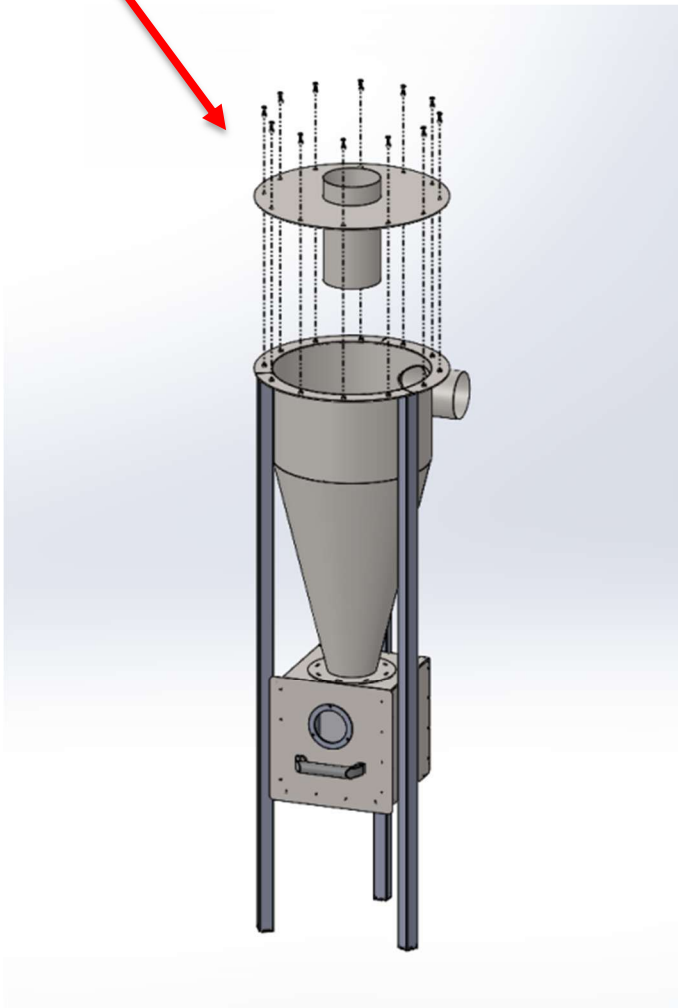
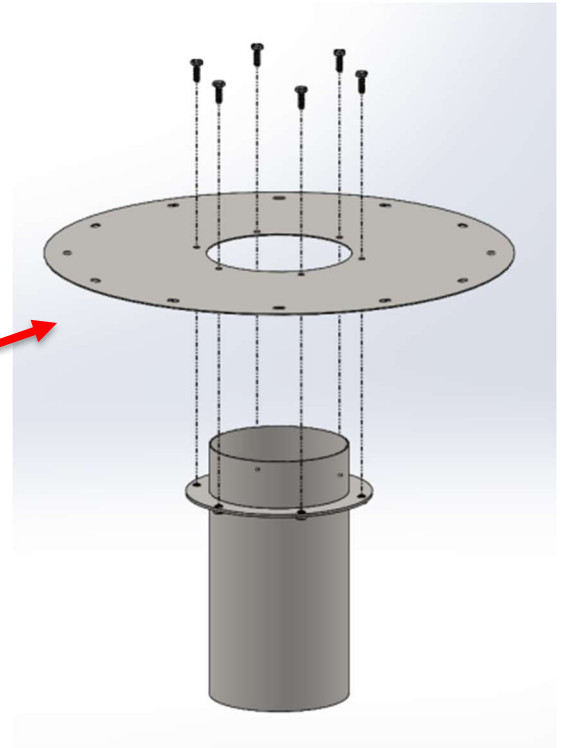

## ASSEMBLING THE BEAN COOLER

1. Remove the Bean Cooler from the pallet and place it on the right side of the roaster. Grab the Bean Cooler Tray Handles and hardware kit.
2. To install the handles, place the bolts through the holes on the Bean Cooler Tray from the inside, as shown in the picture to the right. On the outside of the tray, push the handle into the bolt and secure it with the lock washer and nut.
3. Do this three more times, two for each handle and four total.

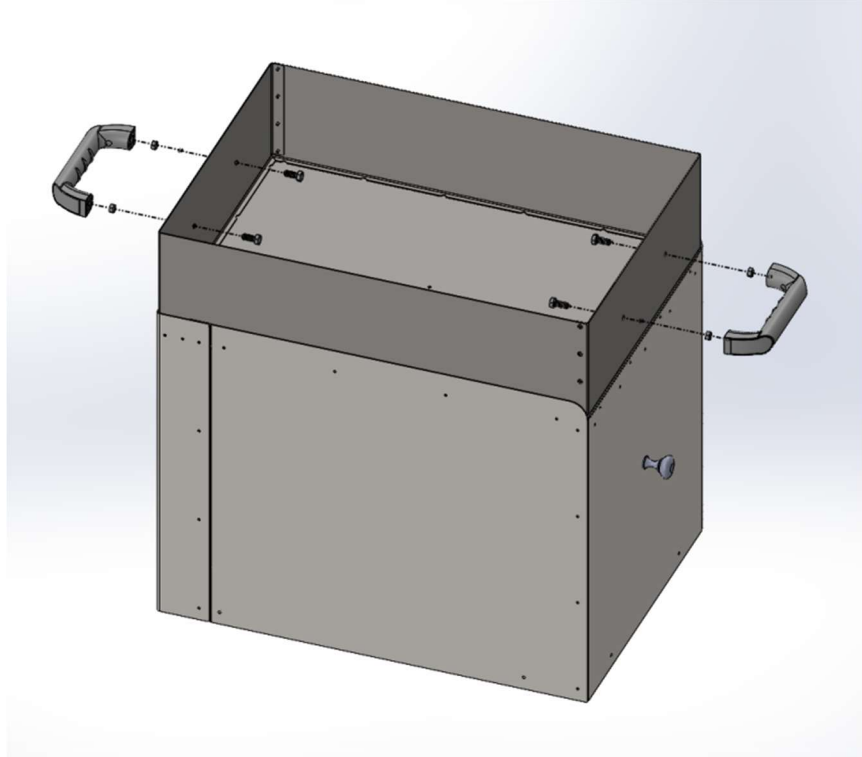

4. Take the tray off and turn the bean cooler upside down.
5. Take the Bean Cooler Exhaust Fitting and push it through the hole on the back of the Bean Cooler with the longer side going in first.
6. The fitting should fit around the 90-degree duct inside the bean cooler. Once in place, secure it with the provided 8/32 keps nuts.
7. Once the fitting is secure, use the provided high temp tape to cover the seem between the fitting and the duct.

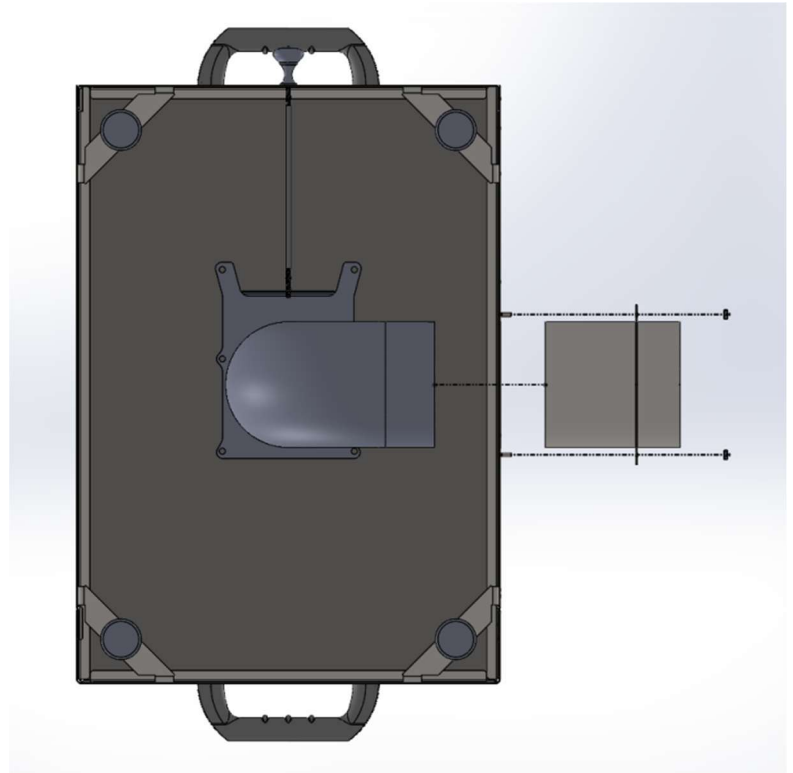

# INSTALLING EXHAUST BLOWER

1. You will need to purchase the proper 20-amp electrical plug that matches the outlet you are plugging the blower into and attach it to your blower wire.
2. Place the 6 X 6 X 6 Wye on the intake side of the blower. Position it as shown in the picture below. Secure the wye with the self-taping screw provided you (attached to the wye in a plastic bag).
3. The exhaust blower comes with a 5-inch flange on the top discharge outlet. We recommend using 5-inch rigid ducting on the discharge side. Be sure to tape the duct seams on the room interior side of the duct system as discharge smoke is under pressure.
4. ***VERY IMPORTANT! All of the duct joints and seams on the discharge and intake sides of the blower must be sealed with high temperature tape. The discharge exhaust ducts are under pressure and will leak smoke into the roasting area if not sealed.***

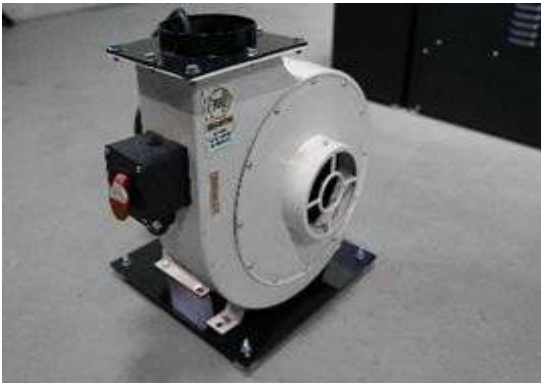

# INSTALLING DUCTING

**NOTE:** Some installations may require longer runs to access a through wall fitting to the outside atmosphere. Use the diagram below to see how the ducting setup should look and then adjust the run from the blower to the outside as needed. The parts in **RED** are duct fittings that are provided by Coffee Crafters. All other ducting parts must be provided by the customer. **USE ONLY RIGID DUCTING**

## Recommended Ducting Setup

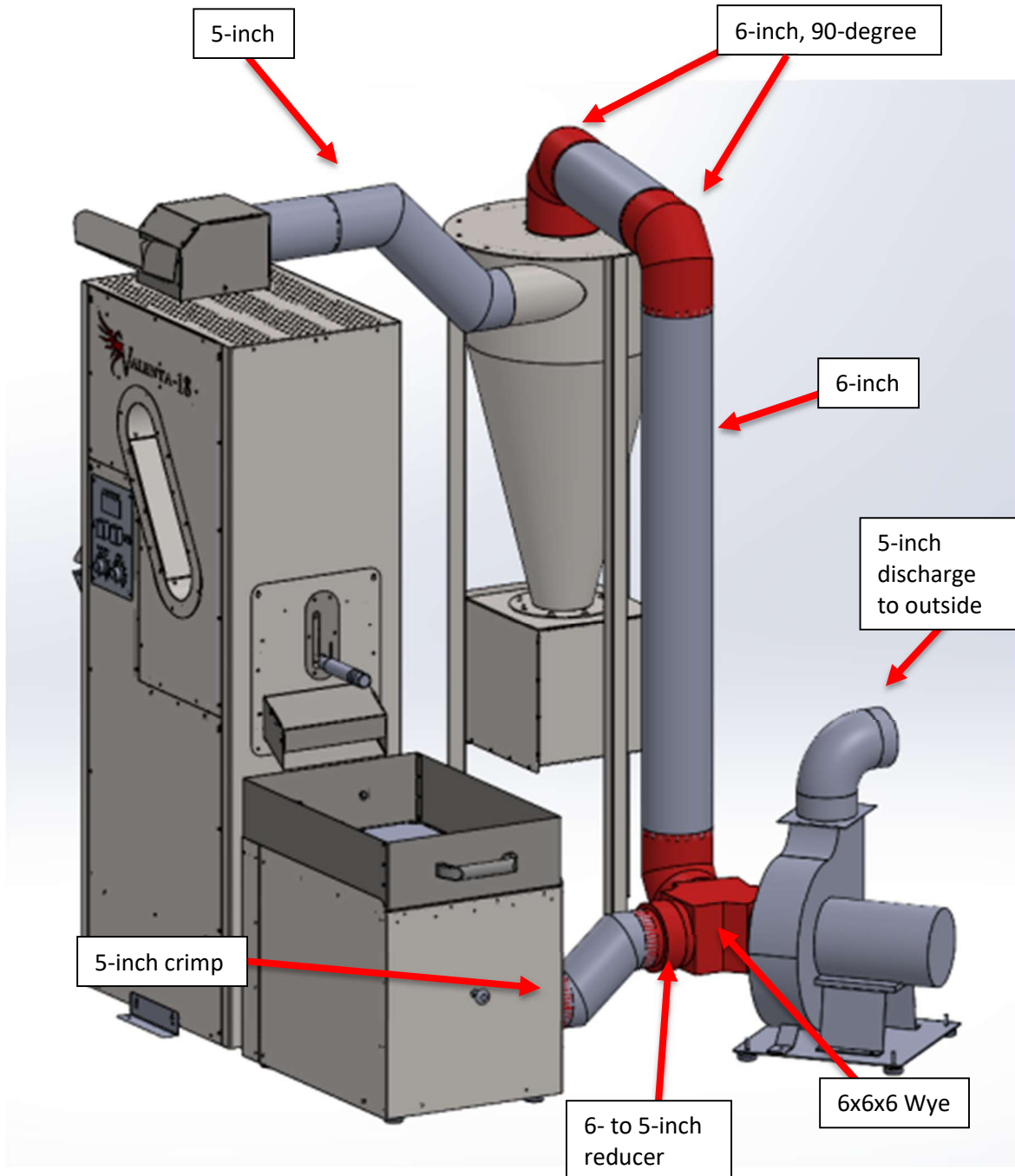

## INSTALLING DUCTING CONTINUED

In order to maximize airflow, it is important to have the ducting run from the exhaust blower to your outside vent as short and as straight as possible.

The picture to the right shows how we would recommend you set up this part of your ducting run. The exit point can be taller or shorter depending on your needs, but this should give you a general idea of what it should look like.



## Ventilation Installation

The Valenta 18 roaster must be exhausted in accordance with the manufacturer's instructions as documented in the prior section of this manual. The roaster exhaust system must be independent of all other systems.

## Exhaust Penetrations

Any wall or ceiling penetration of ducts that transfer roaster exhaust must meet the International Building Code fire-resistance rating and cannot be located within any fire-blocking\* and/or draft-stopping\* areas. Unless such duct work is constructed of galvanized steel or aluminum of a thickness specified in Section 603.3 of the International Building Code and the fire-resistance rating is maintained.

\*Fire-blocking: Prevents movement of flame, smoke, gases through concealed spaces. Primarily addresses vertical movement.

\*Draft-stopping: Prevents movement of smoke and gases through concealed spaces. Primarily addresses horizontal movement.

## Cleanout

All ducting from the blower discharge to the outlet terminal must have a means for cleanout. Exhaust duct cleaning is required for all coffee roasting installations. Inspect exhaust tubing frequently. Clean or replace if excessive build up is present. We recommend you deep clean your ducts at least once a year depending on use.

## Maximum Run Length

While you will want to keep the ducting run from the roaster to the blower as close together as possible, it is important to make sure the ducting run from the blower to the outside is not too long so you can vent all the smoke out of your roasting area. We recommend this ducting run to the outside be no more than 50 feet total, but the shorter the better. See previous example of how the ducting should look when fully assembled.

## Blower Intake to Roaster Ducting

See previous page for more information.

## Blower Discharge Ducting

USE ONLY RIGID ducting from the blower discharge to the outlet terminal.

## Exhaust Gas Temperature

The exhaust gas temperature must not exceed 170° Fahrenheit (76.6° Celsius).

## Light Kit Installation

Take your light kit out of the box and remove the plastic sheath. Place the magnetic base on the left side of the roaster and direct the light beam overtop the loading chute and into the roasting chamber.

Position the light as shown below for optimum brightness inside the hopper. **DO NOT** put the light into the chute, this will cause the light to melt!



## Temperature Switch

The information contained here originated from the manufacturer, LOVE.

Bulletin E-90-TCS



### Series TCS Thermocouple Switch

### Specifications - Installation and Operating Instructions

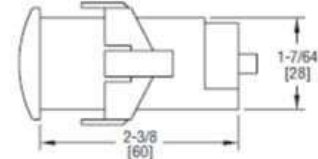
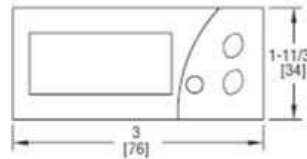

Monitor and control temperature in heating and cooling applications with the Series TCS Thermocouple Switch. The Series TCS offers a wide temperature range, two selectable alarm sets, and an internal buzzer indicating alarm condition or error. The user can define set point, heating/cooling regulation, cycle time, alarm configuration, load status, and ambient probe adjustment. The thermocouple switch features password protection and error/alarm messaging. Temperature and output status is indicated on the bright red LED display. Use the configuration key (sold separately) to quickly program multiple units. The Series TCS includes a fitting clip for panel mounting, gasket, rear terminal cover and instruction manual.

#### INSTALLATION

**Note:** Unit must be mounted away from vibration, impacts, water and corrosive gases.

- Cut hole in panel 2.80 x 1.14 inches (71 x 29 mm).
- Apply silicone (or rubber gasket) around the perimeter of the hole to prevent leakage.
- Insert unit into hole of panel.
- Slide removable fitting clips onto unit from the back until secure to panel.
- Remove back cover to wire unit.
- Wiring diagram is displayed on the top of the unit.
- (Note: PROBE CABLE LENGTH MUST NOT EXCEED 238 ft (100 m). DO NOT INSTALL PROBE CABLE NEAR POWER CABLES).
- Replace cover once wiring is complete.

#### SPECIFICATIONS

**Probe Range:** 32 to 999°F (0 to 700°C) for Type J thermocouple; 32 to 999°F (0 to 999°C) for Type K or S thermocouples.

**Input:** Type J, K or S thermocouple.

**Output:** SPDT relay rated 16A @ 240 VAC resistive.

**Horsepower Rating (HP):** 1 HP.

**Control Type:** ON/OFF.

**Power Requirements:** 115 VAC, 230 VAC, 12 VAC/VDC or 24 VAC/VDC (depending on model).

**Accuracy:** ±1% FS.

**Display:** 3-digit, red, 1/2" (12.7 mm) digits, plus sign.

**Resolution:** 1°.

**Memory Backup:** Nonvolatile memory.

**Temperature Limits:**

Ambient: 32 to 158°F (0 to 70°C);

Storage Temperature: -4 to 176°F (-20 to 80°C).

**Weight:** 2.3 oz (65 g).

**Front Panel Rating:** IP64.

**Agency Approvals:** CE, cUR, UR.

#### WIRING DIAGRAM

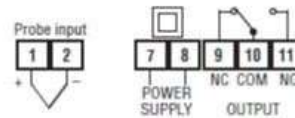

©Copyright 2014 Dwyer Instruments, Inc.

Printed in U.S.A. 2/14

FR# R0-443801-00 Rev.1

**LOVE CONTROLS DIVISION**  
**DWYER INSTRUMENTS INC.**  
 P.O. BOX 338 - MICHIGAN CITY, INDIANA 46360, U.S.A.

Phone: 219/879-8000 [www.love-controls.com](http://www.love-controls.com)  
 Fax: 219/872-9057 e-mail: [love@love-controls.com](mailto:love@love-controls.com)

## Helpful Tips

1. Go to the Maintenance and Troubleshooting section for instructions on proper cleaning of the Valenta 18 Roaster.
2. Your roaster does not require preheating, but you can preheat if desired.
3. Visit our website for roasting tips, the green bean distributor map, and more!



[www.coffeecrafters.com](http://www.coffeecrafters.com)

You are now ready to roast coffee. Proceed to the next section of this manual for initial testing and roasting instructions.

# Roasting

Before roasting your first batch of coffee it's important to orient yourself with proper safety procedures. Treat your roaster the same as you would a cook top range oven. During the roast your roast chamber viewing ports get as hot as any pot on your stove. The air that roasts your coffee reaches temperatures over 500° degrees F.

## Roast Coffee in 6 easy steps:

1. Check the Chaff drawer on the cyclone
2. Turn on Exhaust Blower
3. Turn on System Power Switch
4. Set Bean Loft
5. Load Beans into the hopper through the hood
6. Turn on heating element

### Step 1: Check the Chaff Drawer on the Cyclone

Ensure the chaff drawer is secured in place and less than 50% full before roasting.

### Step 2: Turn on Exhaust Blower

Never run your roaster without the chaff/exhaust blower running. The blower keeps the machine cool and prevents chaff, smoke, and heat from venting into your roast area.

The on/off switch is located on the front or side of the blower motor. This directs all the suction through the ducting, so chaff does not escape.



Exhaust Blower switch

**If this is your first roast of the day, preheat your Valenta 18 Roaster before you start roasting by turning on the loft to 3 and heat to 10 until you see the roast air temperature read 450 degrees F (usually 1 minute).**

### Step 3: Turn on System Power Switch

The system power switch is the single red switch to the left. As a safety feature the heat elements cannot be turned on with the system power switch in the off position.



## Step 4: Set the Bean Loft

The bean loft blower knob is marked low to high. **Remember; never load the beans into the hopper until you have established the loft!** This prevents beans from being burned in the hopper (especially every roast after your first roast of the day as the heating elements will still be very hot). Slowly turn up the air by turning the knob clockwise. Practice this several times before turning on the heat to familiarize yourself with the feel of lofting beans.

**Set the bean loft according to the recommended setting on page 28. Please note: You will set the loft at a slightly higher setting while loading the beans and then you may need to turn it down slightly while roasting. This is a safety precaution because the beans will burn very quickly if they are not moving the entire time they are in the hopper. Once the beans are in the hopper, you can turn down the loft slightly so the beans can settle into their roasting cycle.**

### CAUTION:

Never let the beans stop lofting with the heat elements on. You will burn your beans and possibly damage your Roaster.

One of the heat elements will always be ON when the heat setting switch is in the ON position, even if the setting is ZERO. Make sure to always have the loft ON when the heat elements are ON or you will damage your Roaster!

Airflow simulation

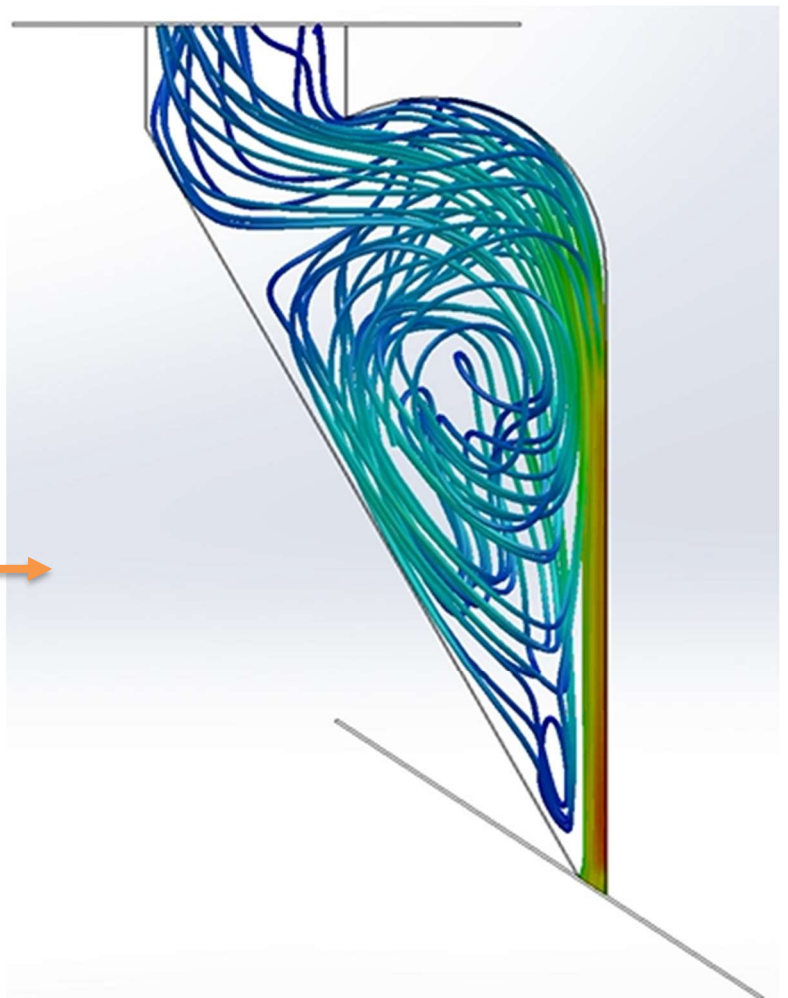

### Step 5: Load Beans in Top Hopper

Make sure your air loft adjustment is on prior to pouring in the beans.  
Load the beans into bean hopper by pouring the beans down the loading chute. We recommend using food grade buckets for the pouring process.



## Step 6: Turn on Heating Element

1. Turn on the heating elements switch.
2. Use the heat adjustment knob (measured from 1 to 10) to the left of the Temperature Controller to set the heat for your batch size.
3. Re-adjust your bean loft if needed-sometimes the loft decreases after the heat switch is turned on.

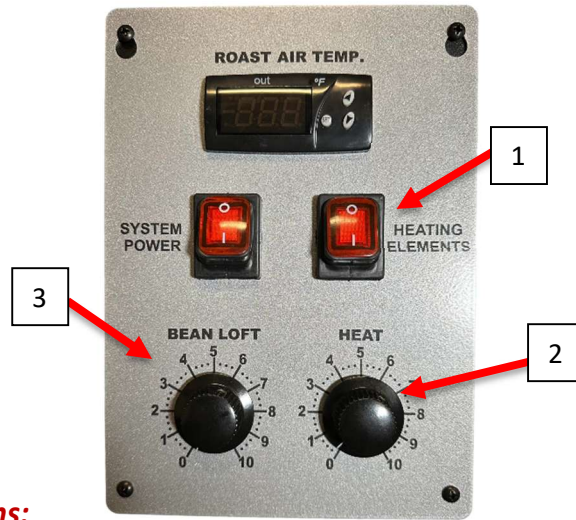

### Roasting Recommendations:

BATCH SIZE IN LBS	Loft Setting	HEAT SETTING
2 (min)	2	3.5
4	2.25	4
6	2.75	4.75
8	3	5
10	3.25	5.5
12	3.75	6.5
18 (max)	4.25	10

**NOTE:** These are only recommendations and may vary based on altitude, humidity, line voltage and ambient air temperature.

You can increase or decrease the heat setting to achieve the temperature you need.

Roasting times may vary due to room temperature, or if machine is warm or cold. Always monitor the batch while roasting, NEVER leave unattended and watch the bean temperature to achieve the desired roast. You will quickly learn which settings work best for your roasting style.

If roasting below a 2 lb. batch, the bean temperature may not read accurately.

Roasting on the Valenta 18 is very easy. Never leave your roaster unattended. If you lose your bean loft you will ruin your batch and possibly damage your Roaster. **Coffee beans will catch on fire if they stop circulating!**

## Roasting Complete: Cool the Beans

Coffee beans must be cooled quickly after you reach your desired bean temperature. You can see into the roast chamber as the roast progresses, but a good rule of thumb is to stop your roast a few degrees before you reach your desired temperature. With the light shining in the hopper, the beans look lighter than they do when removed from the hopper.

1. Open the bean cooler blast gate.
2. Turn off the Heat element switch.
3. Turn off the loft.
4. Lift the dump gate and let the beans fall into the bean cooling tray.



With the beans in the cooling tray, stir the beans occasionally with a spoon to make sure no hot spots remain in the corners. As you stir your beans, this is a good time to check for any rocks or foreign objects. Cooling takes about 90 seconds for smaller loads and about 2 ½ minutes for larger loads.

After your beans are sufficiently cooled down, return the cooling knob to its original position closing the air tube under the perforated tray. Our tray is designed to be removed for easy pouring of roasted beans.



# Coffee Bean Education

## Proper Storage of Green Coffee Beans

The two most important variables for storing your beans are humidity and temperature.

Your green beans will keep for over 2 years when stored properly.

Some good tips to keep in mind:

- Store beans between 50-85° F (If the temperature is comfortable for you, it's comfortable for your beans)
- If you purchased full bags, keep beans in the jute bag they came in for good breathability
- Keep your beans off the ground (wood pallets work best). This helps promote all around air circulation and prevents condensation
- Keep away from pets
- Place beans away from sink and water sources

Things to avoid:

- High humidity
- Changes in temperature
- Direct sunlight

If you are purchasing smaller quantities and don't plan on storing your beans for long periods of time, storing your beans in food grade buckets will work well. These Gamma screw lids give an airtight seal and are easy to open/close (available on Amazon).



Another great, but expensive, storage option is to keep beans in vacuum sealed bags. Vacuum packed beans do not need to be monitored as much since they are not exposed to oxygen and atmospheric moisture.

## Green Coffee Bean Abbreviations and Meanings

**SSFC** – Strictly Soft Fine Cup – Grown at relatively low altitudes (under 1200 meters). These beans mature quickly and produce a lighter, less dense bean. This term also means the beans are free of hard riyoy taints. Fine cup means it is a specialty grade coffee.

**RFA** – Rain Forest Alliance – Meets the standards that are intended to protect the environment and the rights of workers.

**FTO** – Fair Trade Organic – Certified as a fair-trade bean with Organic classification.

**FT** – Fair Trade – Certified as a fair-trade bean.

**EP** – European Preparation – These beans are hand sorted to remove any defective beans and foreign material.

**SHB** – Strictly Hard Beans – Grown at an altitude above 1350 meters.

**SWP** – Swiss Water Process – Decaffeinating process that includes a “flavor charged” water. 100% chemical free.

**MWP** – Mountain Water Process – Decaffeinating process that results in flavorful beans that are 99.9% caffeine free.

**MC** – Methylene Chloride – Used to decaffeinate coffee and some believe it to maintain coffee flavor better than other processes.

**EA** – Ethyl Acetate – An ester found naturally in fruits and vegetables that is used to decaffeinate coffee.

**SHG** – Strictly High Grown – This classification is higher than HB (Hard bean).

**AA** – Reference to a 17/18 screen size.

**AB** – Refers to size. AB consists of both A and B coffee beans; screen sizes 15 and 16. AB are smaller than AA and not as valued.

**Fancy** – Refers to better quality than average specialty quality for Arabica beans.

**17/18** – Refers to screen size. The larger bean size generally correlates to a higher quality bean.

**Rioy Taints** – Defect in the bean resulted from an over ripened cherry.

**Quaker** – Defect in bean. Unripe cherry.

# Maintenance and Troubleshooting

## Maintenance

Your Roaster requires periodic maintenance and cleaning. Maintenance and cleaning will be dependent on the amount of coffee you roast. You should be cleaning your ducting at least once per year.

## Chaff Drawer

Every time you roast, inspect the condition of the chaff drawer. When it becomes over halfway full, empty the drawer into a trash bin. Dirty chaff drawers can be washed with a mild detergent and air dried completely to use again.

Inside the chaff drawer unit can be vacuumed.

## Roast Hopper Cleaning

Please refer to our YouTube video on removing and cleaning the hopper:

Coming Soon

## Bean Cooling Tray

With use, especially with darker roasts, you will notice a buildup of oils inside your cooling tray. Remove the tray and wash with warm soapy water, rinsing and drying well. When the tray is removed from the cooling unit, take this time to clean out any beans that have fallen into the cooling void under the tray. A vacuum will remove the dust and beans then you can wipe out this area with a damp cloth.

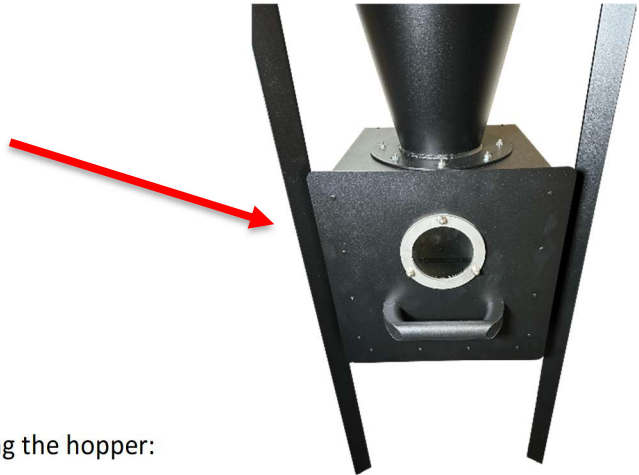

## Exhaust Tubing

**\*\*IMPORTANT- Make sure to unplug the blower before attempting any of the following steps\*\***

You will need to access the inside of the rigid exhaust tubing to be able to run a brush down the inside of the tubing. If you have elbows in your exhaust tube line, you may have to take apart your line to fully clean the exhaust tubes.

After the rigid tubing is cleaned, inspect the inside of your blower prior to reinstalling the tubing. Take a plastic brush and go over each fin on the inside of the blower. Once everything is reattached, turning on the blower will remove the debris. (See YouTube video on blower cleaning)

Depending on how many pounds (lbs.) of beans you roast daily will determine how often you clean your duct tubing. The buildup of chaff dust can present a fire hazard. When the inside of the tubing is completely covered with dust, it is a good time to clean it. (See YouTube video on venting)

## Exterior Surfaces

The body of the Roaster can be washed down with a damp cloth or mild detergent. Do not use industrial spray cleaners/degreasers on your roaster.

## Troubleshooting

This portion of the manual is intended to provide guidance for roaster owners and qualified repair persons working on the Valenta 18.

Mechanical and operational issues most commonly experienced by customers are addressed. The Valenta 18 has proven to be a very reliable machine but like all mechanical devices, things will go wrong.

Coffee Crafters roasters are designed from the ground up to be very easy to operate and maintain. All wiring is color coded and labeled. Additionally, videos are available on our YouTube channel on changing most of the machine components.

Coffee Crafters maintains a full inventory of replacement parts. Please refer to the Parts List section of this manual when ordering. Your machine serial number can be found on the back of the roaster above the power distribution block on the back of your machine. Please include your machine serial number when making inquiries about your machine. Coffee Crafters maintains a history of your machine accessible with your machine serial number.

<b>Problem</b>	<b>Cause(s)</b>	<b>Solution</b>
Exhaust blower starts to lose suction	<ol style="list-style-type: none"><li>1. An obstruction in the vent pipe.</li><li>2. The bean cooler blast gate is open.</li></ol>	<ol style="list-style-type: none"><li>1. Check the vent pipe from the blower discharge through the through wall fitting. Remove obstruction or replace damaged duct pipe.</li><li>2. Close the bean cooler blast gate while roasting.</li></ol>

Problem	Cause(s)	Solution
Bean Loft motor won't start.	<ol style="list-style-type: none"> <li>1. System power switch is in the "off" position.</li> <li>2. Tripped system powerfuse.</li> <li>3. Faulty system power switch.</li> <li>4. SSR-3 has failed.</li> <li>5. Faulty potentiometer.</li> </ol>	<ol style="list-style-type: none"> <li>1. Ensure system power switch is in the "on" position.</li> <li>2. Check for tripped system power fuse located on the left side of the machine.</li> <li>3. Check system power switch voltage when in the 'on' position. If no voltage, replace switch.</li> <li>4. Check SSR-3 voltage output. If no voltage output, replace SSR-3.</li> <li>5. Check motor speed control potentiometer for linear resistance. If ohms of resistance do not reduce to "0" when potentiometer is turned all the way up, replace potentiometer.</li> </ol> <p>Note: A tripped system power fuse is an indication that a fault has occurred in the system.</p> <p>If by resetting the fuse, it does not come on, call the manufacturer.</p>

<b>Problem</b>	<b>Cause(s)</b>	<b>Solution</b>
Bean Loft motor powers up but elements won't turn on.	<ol style="list-style-type: none"> <li>1. Heat element switch failed.</li> <li>2. Faulty connector on input side of heat switch.</li> <li>3. Temperature controller setting.</li> <li>4. Faulty temperature controller.</li> </ol>	<ol style="list-style-type: none"> <li>1. Replace heat element switch.</li> <li>2. Replace connector and heat switch.</li> <li>3. Check the roast air temperature control setting. Roast air temperature must be set higher than your desired ending bean temperature.</li> <li>4. Replace temperature controller.</li> </ol> <p>Note: The system power switch supplies power to the input of the heat switches when in the "on" position. If the heat elements do not come on when the heat switch is turned "on", check the voltage on the output of the heat switch (center terminal). If no voltage, replace switch.</p>

<b>Problem</b>	<b>Cause(s)</b>	<b>Solution</b>
Speed control knob will not reduce bean loft motor RPM.	<ol style="list-style-type: none"> <li>1. SSR-3 has failed.</li> <li>2. Motor speed control potentiometer has failed.</li> </ol>	<ol style="list-style-type: none"> <li>1. Replace SSR-3.</li> <li>2. Replace motor speed control potentiometer.</li> </ol>

Problem	Cause(s)	Solution
Heat elements running but roasts take too long.	<ol style="list-style-type: none"> <li data-bbox="412 266 755 331">1. Ambient air temperature is too low.</li> <li data-bbox="412 373 651 405">2. Low line voltage.</li> </ol>	<ol style="list-style-type: none"> <li data-bbox="784 266 1419 365">1. Roast smaller loads until you identify maximum load size where machine can reach optimum roast air temperature.</li> <li data-bbox="784 443 1195 474">2. Install a buck boost transformer.</li> </ol> <p data-bbox="784 516 1446 615">Note: Roasting in cold environments below 50° Fahrenheit will increase roast times. We suggest roasting in an enclosed, heated environment if in cold weather.</p> <p data-bbox="784 657 1425 863">The roaster does not perform well under 235-line voltage under load. If you confirm that both heat elements are running but have trouble achieving your desired roast air temperature with full loads, have a qualified electrician check your line voltage under load or use a voltage meter to check your line voltage under full load.</p>
Air coming out of Dump Gate.	<ol style="list-style-type: none"> <li data-bbox="412 871 662 936">1. Dump gate needs adjusting.</li> </ol>	<ol style="list-style-type: none"> <li data-bbox="784 871 1219 936">1. See video on adjusting Dump Gate (Coming soon)</li> </ol>



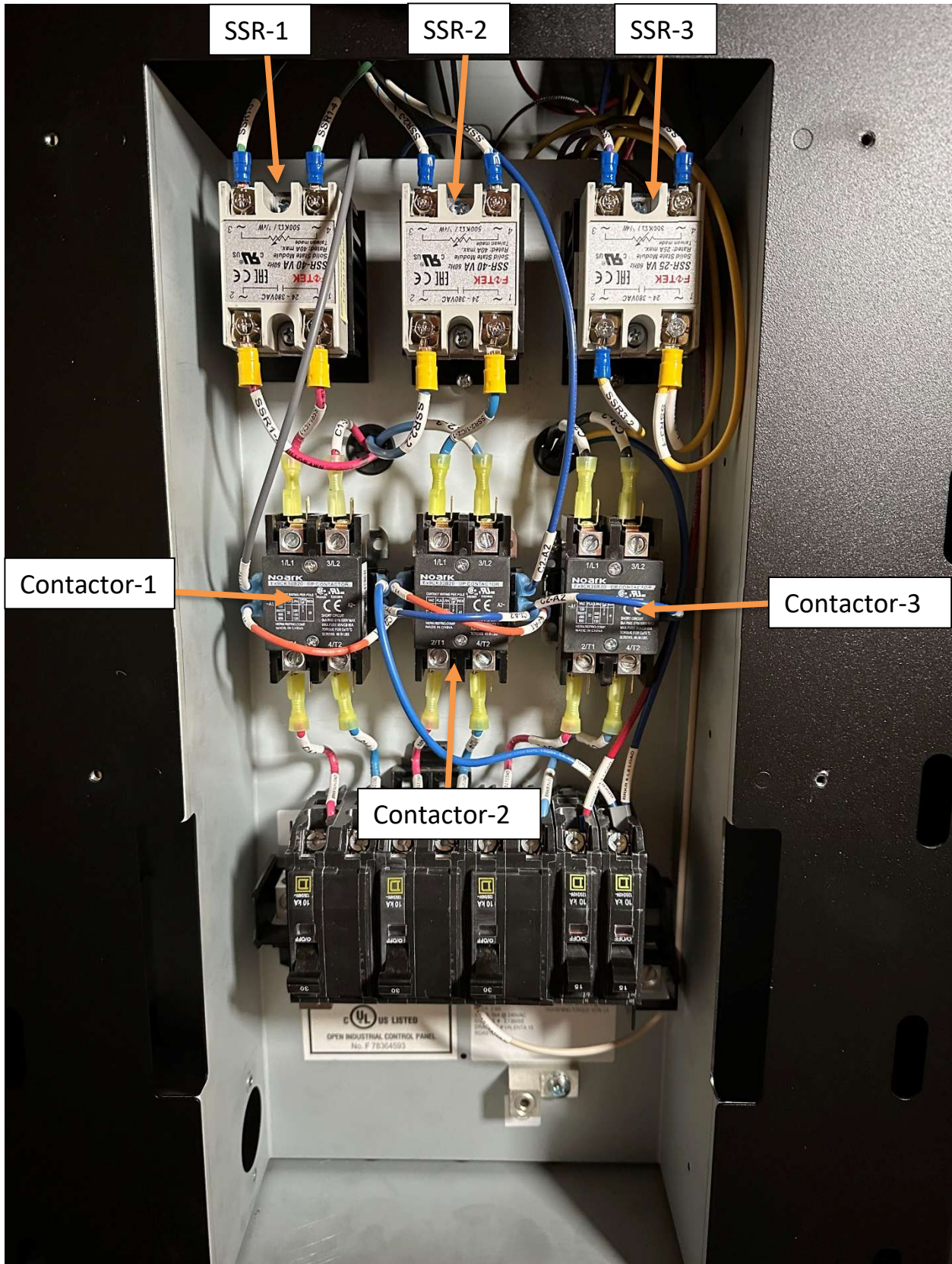

Note that the SSR's are installed with the writing upside down. Potentiometer connections are on the top, power connections are on the bottom.

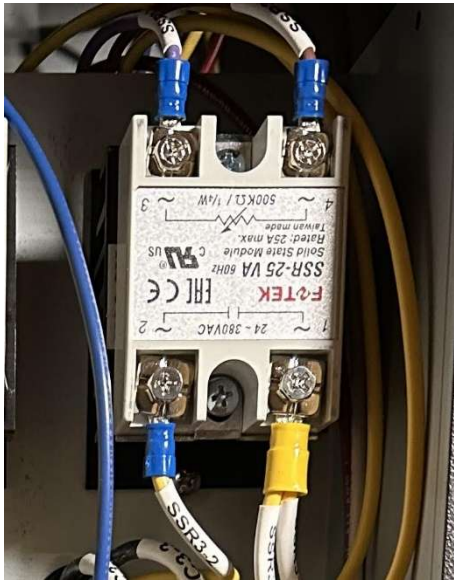

**SSR 3**

**Motor Speed Control Module**



**SSR 1 and 2**

**Heat Control Modules**

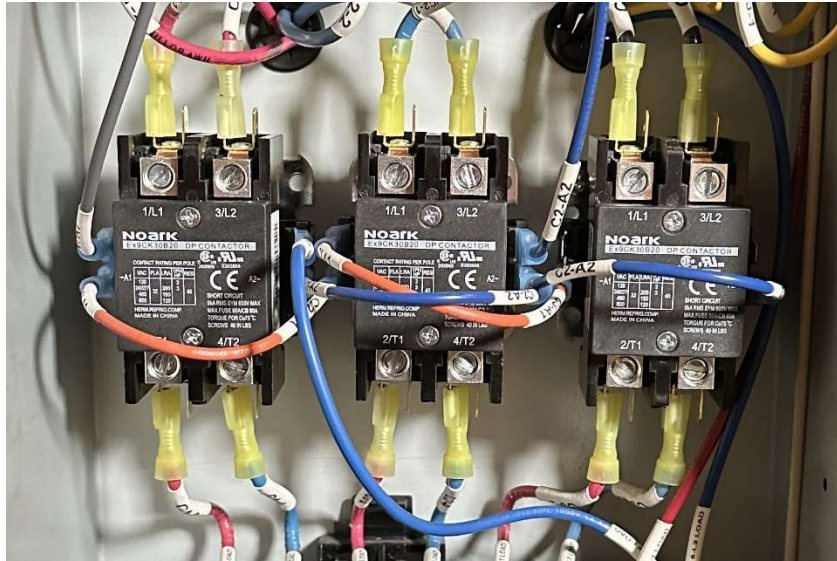

Noark Contactors





# Part List

Part Name	Part Number
Bean Temperature Probe (21")	WRN-535-1000
Borosilicate Glass (16GA)	V15-RCG-1040
Chansen Blower	CHANSEN
Chansen Blower Capacitor	#24-3 capacitor chansen
Chansen Blower Switch	#29-#34 switch & cover
Digital Thermometer	SK-86460-03
Door Gasket	V15-RCD-2000
Double Potentiometer (heat)	R-VA2XXL 500K
Fotek SSR-25	SSR 25-VA 1/4 watt
Fotek SSR-40	SSR-40VA
Glass Gasket	V15-RCG-1020
Heat Element	13-25146-00
Loading Chute	V15-LCA-1000
Loft Motor	CC-2165-00 BLB
Loft Motor Brushes	8505969-20
Blower Motor Sliding Mount	V15-BSM-1000
Noark Contactor	EX9CK30B20
Roast Air Temp. Probe	WRN-535-1200
Motor Inlet Air Temp. Probe	WRN-535-148cm
Roast Chamber Mount Gasket	V15-RCA-2000
Roaster Light	JT1MCJSGP pinyuan_JC8001
Single Potentiometer (loft)	023-638
Starter Capacitor	#24-3 capacitor chansen
Switch x2	KCD4 30A
Temperature Controller	TCS-4020
Thermometer	SK-86460-03
Thermometer Bracket	A9-HTM-1000
Thermometer Bracket Base	V15-TBS-1000
Wye Duct 6x6x6	FY6



