



# Coffee Crafters



## Valenta 3 Base Model

### 3-lb. Fluid Bed Commercial Coffee Roaster Manual

708 S. Clearwater Loop Ste 105  
Post Falls, ID 83854

[www.coffeecrafters.com](http://www.coffeecrafters.com)

Phone (509)228-6916

[info@coffeecrafters.com](mailto:info@coffeecrafters.com)

Copyright © 2024 Coffee Crafters LLC All Rights Reserved

# Contents

Introduction .....	4
About Us .....	4
Our Mission .....	4
Our Vision .....	4
Valenta 3 Model Complete Roasting & Bean Cooling System Specifications .....	5
Warranty And Guarantee.....	6
Valenta 3 Model Warranty .....	6
What Is Not Covered by The Warranty.....	6
Assembly And Installation.....	8
Assembly Introduction.....	8
Hardware Packages .....	8
Installing Hood/Mast.....	10
Thermometer .....	11
Mounting Thermometer Bracket to Roaster.....	12
Attaching Probe .....	13
Attaching Dump Handle .....	14
Installing Power Cord.....	15
Installing Exhaust Blower.....	16
Installing Flex Tubing .....	17
Installing Exhaust Blower cont. ....	18
Installing Chaff Bag Bracket.....	19
Ventilation Installation .....	20
Light Installation .....	21
Temperature Switch .....	22
Helpful Tips.....	23
Roasting .....	24
Roast Coffee In 6 Easy Steps.....	24
Step 1: Check Chaff Bag .....	24
Step 2: Turn On Exhaust Blower .....	24
Step 3: Turn On System Power Switch .....	25
Step 4: Set Bean Loft.....	26
Step 5: Load Beans into Bean Hopper .....	27

Step 6: Turn on Heating Element .....	28
Roasting Complete: Cool the Beans.....	29-30
Coffee Bean Education .....	31
Proper Storage of Green Coffee Beans.....	31
Green Coffee Bean Abbreviations and Meanings.....	32
Maintenance And Troubleshooting.....	33
Maintenance.....	33
Chaff Bags .....	33
Roast Hopper Cleaning .....	33
Bean Cooling Tray .....	33
Mast Tubing.....	34
Exhaust Tubing .....	35
Exterior Surfaces.....	35
Troubleshooting .....	36-39
Exhaust Blower Losing Suction.....	36
Bean Loft Motor Won't Run .....	37
Both Heat Elements Won't Turn On.....	38
Bean Loft Motor Runs at Full Speed Only.....	38
Both Elements Running but Roasts Take Too Long .....	39
Air Coming Out of Dump Gate .....	39
Troubleshooting Figure 1.1 .....	40
Troubleshooting Figure 1.3 .....	41
Troubleshooting Figure 1.4 – SSR Connections.....	42
Troubleshooting Figure 1.5 – Contactors.....	43
Wiring Diagram USA.....	44
Wiring Diagram EUR .....	45
Part List.....	46

# Introduction

In this manual, you will find everything needed to start roasting coffee. Included in this copy is a description of your warranty/guarantee, detailed information on installation and assembly, roasting instructions, additional information on green beans, and a troubleshooting guide.

## About Us

While living in Thailand and unable to find fresh roasted coffee, Ken Lathrop, developer of Coffee Crafter's Valenta 3 coffee roaster, conceived of a concept to design and build a reliable, affordable machine capable of roasting five pounds or more of coffee beans in less than ten minutes.

"My goal was to enable new roasters – to help them roast their own beans and have fun doing it", says Lathrop. "My focus was to design and build a roaster that could be easy for anyone to learn and use, a roaster that could roast five pounds or more per roast batch and was easily installed and affordable for anyone. From the response we have received from customers and at coffee shows I think we succeeded."

Coffee Crafters designed and began selling its Artisan V fluid bed coffee roaster in August 2013. "We built the Artisan roaster specifically to serve small roasters or those new to the industry", says Lathrop. "The installation is similar to your home clothes dryer – very simple and straightforward. After installation we find that our customers are up to speed and roasting typically within 30 minutes."

## Our Mission

To become the best and largest supplier of high-quality affordable coffee "micro-roasting" equipment in the world.

**"Micro-Roasting" defined:**

1. Hands on craft roasted coffee
2. Roasting 1,000 lbs. or less per day
3. Supply "fresh" coffee to Customers immediately after roasting at its peak of freshness

## Our Vision

We will maintain an uncompromising commitment to our "micro-roasting" customers by:

- Serving our customers the way we would like to be taken care of.
- Providing our customers with equipment, supplies and information to satisfy all of their micro-roasting needs.
- Supplying high quality products engineered and manufactured in the USA.
- Delivering affordable equipment factory direct.



## Valenta 3 Base Model

Energy Efficient Fluid Bed  
Coffee Roasting System

### Valenta 3 Roasting & Bean Cooling System Specifications

Roaster Production	Up to 21 lbs. per hour
Roast Time	6-10 minutes (manually adjustable)
Chaff Collection	Vent kit with outdoor chaff collector fitting/bag
Bean Cooling	External 3 lbs. capacity
Roast Air Temperature	Variable manual control Fahrenheit or Celsius
Bean Temperature Thermometer	Included
Roaster Power	Single-phase 240v at 30-amps
Exhaust System Power	Blower not included
Roaster Heat	5,200 watts
Batch Size	200g to 3 lbs
Venting	Intake: 4" flex ducting (provided) Discharge: 5" rigid ducting (not included)
Minimum Floor Space for full system	32 inches long by 42 inches wide

### Dimensions & Weight

Roaster	30.7" tall x 18.8" deep x 45.1" wide
Minimum Floor Space Needed	45.1" by 20"
Shipping Weight	Roaster Box 70 lbs., Accessory Box 17 lbs
Shipping Dimensions	Roaster Box 36" x 16.5" x 31.5" Accessory Box 24" x 14" x 10"

### Electricity Usage

Full 3 lb. load	0.3 kWh per pound
1 lbs. load	0.6 kWh per pound

### Certification

UL

CE

Coffee Crafters  
708 S Clearwater Loop, Suite 105, Post Falls, ID 83854  
(509)228-6916 – [sales@coffeecrafters.com](mailto:sales@coffeecrafters.com)

# Warranty and Guarantee

## Valenta 3 Model Warranty

Your Valenta 3 Roaster has been manufactured and tested to the highest quality standards by Coffee Crafters. This Limited Warranty covers defects in material or workmanship on new Valenta roasters. The Warranty extends to the original purchaser only and is non-transferable. Only consumers purchasing roasters from Coffee Crafters may obtain coverage under our limited warranty.

Coffee Crafters warrants this product against defects in material or workmanship as follows:

- Under normal installation per Coffee Crafters instructions, use, service, and maintenance for a period of one year from the original purchase date, Coffee Crafters will replace at no charge, any product or part of the product that proves defective because of improper workmanship and/or material.

The specific warranties expressed are the ONLY warranties provided by the manufacturer. These warranties give you specific legal rights, and you may also have other rights which vary from state to state.

## What is Not Covered by the Warranty

1. Conditions and damages resulting from any of the following:
  - a. Improper installation, delivery, or maintenance.
  - b. Any repair, modification, alteration, or adjustment not authorized by the manufacturer.
  - c. Misuse, abuse, accidents, unreasonable use, or acts of God.
  - d. Incorrect electric current, voltage.
  - e. Improper setting of any control.
  - f. Use of risers (pedestals) that are not authorized by the manufacturer.
  - g. The Warranty is void if a product is returned with removed, damaged, or tampered labels or equipment, or any alterations.
2. The Warranty is void if the original serial numbers have been removed, altered, or cannot be readily determined.
3. Chaff Filters.
4. Products purchased for use other than roasting coffee.
5. Any food loss due to product failures.
6. Expenses for travel and transportation for product service.
7. Consequential or incidental damages sustained by any person as a result of any breach of these warranties. Some states do not allow the exclusion or limitation of consequential or incidental damages, so the above exclusion may not apply.

## If You Need Service

1. See the Maintenance/Troubleshooting section of this manual.
2. Visit our YouTube channel to find Maintenance and Troubleshooting videos for tips on fixing/replacing roaster parts
3. If you are still having issues with the roaster, give us a call or send us an email so we can figure out the problem with you.
  - Phone: 509-228-6916
  - Email: [info@coffeecrafters.com](mailto:info@coffeecrafters.com)

## 30-Day Complete Satisfaction & Money-Back Guarantee

We want you to be fully satisfied with every item that you purchase from Coffee Crafters. If you are not satisfied with an item that you have purchased, you may return the item within 30 days of purchase date for a full refund of the purchase price, minus the shipping, handling, or other additional charges.

## Return Instructions

Please note: For the purposes of tracking and insurance, all returns must be shipped to Coffee Crafters.

1. Pack the item securely in the original package, if possible. Enclose the return portion of the original packing slip with the item.
2. All products must be returned in excellent condition, in original boxes, and with all paperwork, parts and accessories to ensure full credit.
3. All return shipping charges must be prepaid. We cannot accept C.O.D. deliveries.
4. Keep the Return Tracking Number from the package you are returning to ensure that the package is returned to the warehouse.
5. You can expect a refund in the same form of payment originally used for purchase usually within 10-15 business days of our receiving your returned product. Returned funds may reflect charges for incomplete components or damaged materials. Delays may be experienced in the case of incomplete returns. Please note that your shipping costs will not be refunded.

## Receipt of Damaged or Defective Items

If you receive a damaged or defective item, contact Coffee Crafters Customer Service Department at 1-509-228-6916 immediately upon receiving the item. Please supply your order number, item number and tracking number from your original confirmation e-mail. Coffee Crafters will also need your e-mail address and phone number.

A defective item may be repaired or replaced within 30 days of purchase under Coffee Crafters Warranty.

# Assembly and Installation

## Assembly Introduction

Your Valenta 3 roaster comes mostly assembled. The following instructions will help you complete the assembly process correctly.

Before you start the assembly process you must select a suitable location for the Roaster and Blower System. The Blower System can be installed in any location within 10 feet of the roaster including on the other side of a wall. You may prefer this installation method if the noise is an issue. The customer must supply the 4" or 5" rigid ducting for outside venting. If you decide to put the Blower System in a different location additional vent pipe and fittings will be required. Make sure to check with local codes for venting requirements as noted in the ventilation installation section of this manual. When correctly installed, the exhaust gas temperature will not exceed 170° Fahrenheit.

The Roaster must be positioned on a flat smooth surface, do not install on carpet. Make sure the Roaster has at least a 6-inch gap between the back vent pipes and the wall.

## Hardware Packages

Your Valenta 3 roaster comes with all the fittings and hardware needed to install the roaster, bean cooler and exhaust blower. Not included is the electrical cord or ducting on the discharge side of the exhaust blower. A complete list of included hardware and fittings and listed below.

1. Hood Hardware
  - a. (2) 8/32 by 3/8" screws
  
2. Thermometer Bracket
  - a. (3) 8/32 by 1/2" screws
  
3. Bean Cooler Bracket and Wye Duct
  - a. (2) Self Tapping Screws

# ASSEMBLING YOUR VALENTA 3 ROASTER



## ACCESSORY KIT



## VALENTA 3 HOOD MAST INSTALLATION

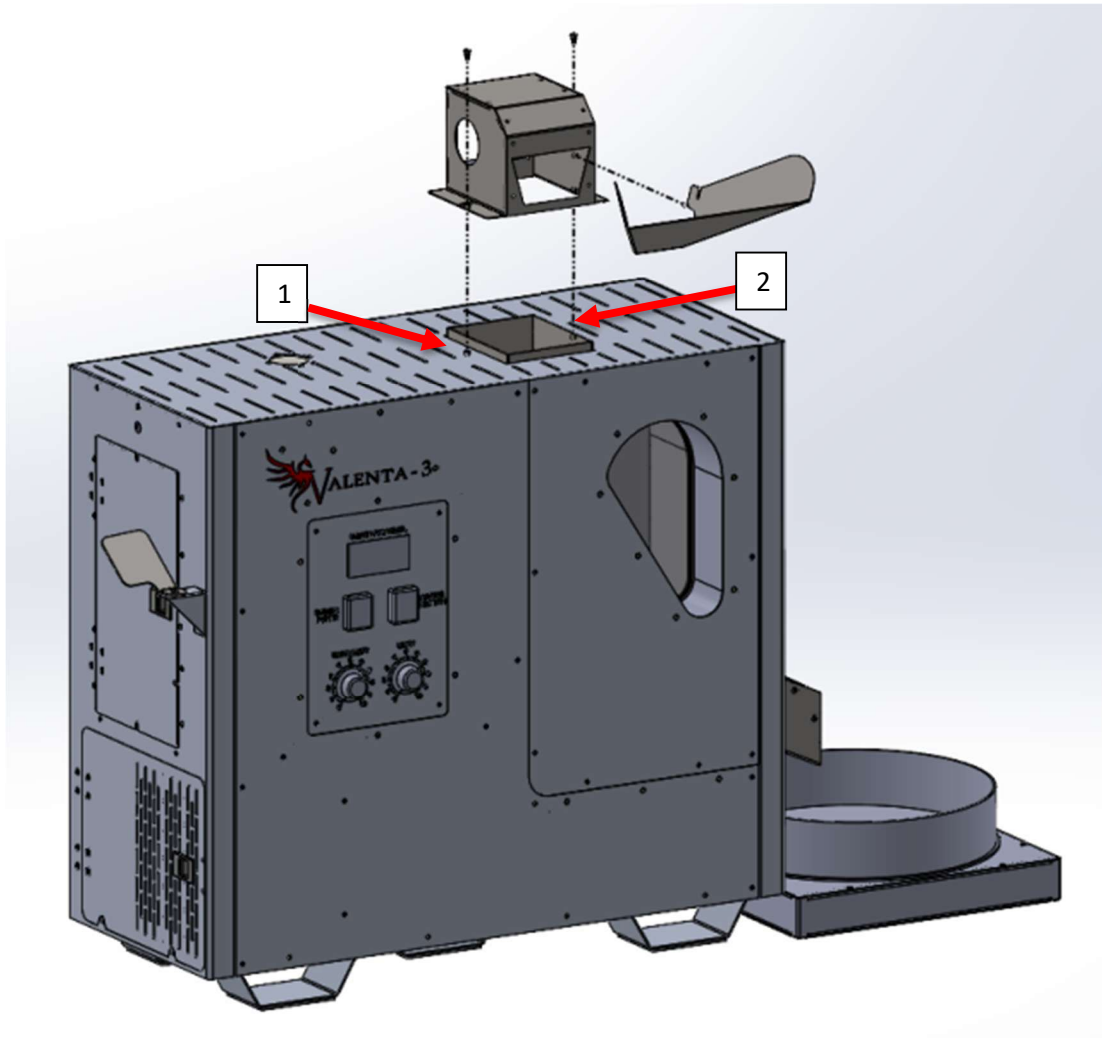

Slide the hood over the square hole on the top of the roaster as shown above. Secure the hood with the provided 2 – 8/32 screws and tighten down. Attach the bean loading chute to the front of the hood.

## Thermometer

Your thermometer will be placed on the Thermometer bracket located on the left side of the roaster.

The Digi-Sense Thermometer is very easy to operate (pictured). The large display makes the bean temperature reading easy to see. There are only a few basic operating functions.

1. The meter has an auto off function and will power down after 30 minutes with no key operation. To disable the auto power off mode, press and hold the "H" and "Power" keys at the same time. The clock dial in the upper left corner of the screen will disappear and the auto off will be disabled.
2. When the battery voltage is under the proper operation requirements the low battery symbol will show on the LCD screen and the battery will need to be replaced.



The thermometer comes to you with the battery and thermocouple probe installed and tested. Velcro has been applied to the back of the thermometer. To install it on the thermometer bracket, remove the plastic from the Velcro and install on the bracket as shown in the picture below. The bottom of the thermometer should be even with the bottom of the thermometer bracket.

## Mounting the Thermometer Bracket to Roaster

**Step 1:** Attach bracket base to the two the protruding studs on the left side of the roaster. Tighten with two 8/32 screws. Use another 8/32 screw to attach bracket to the base.

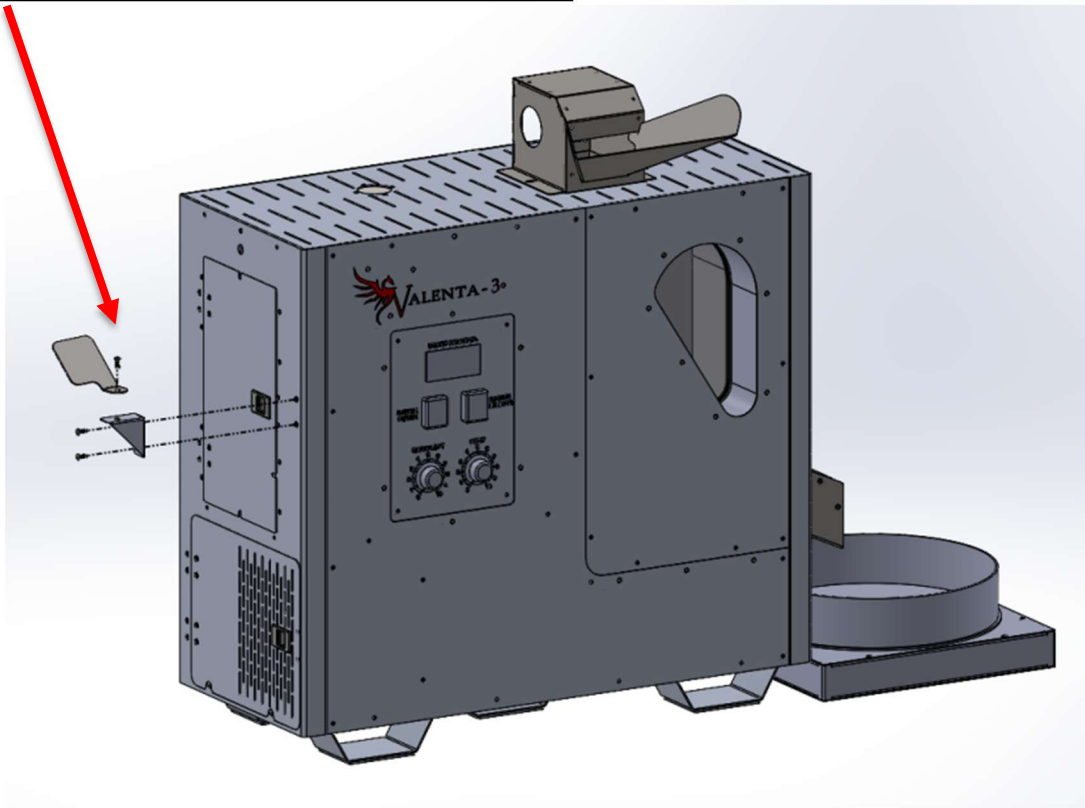

**Step 2:** Peel the sticker off the back of the thermometer Velcro strips.



**Step 3:** Secure thermometer to thermometer bracket as shown and press firmly.



## Attaching the Thermocouple Probe

**Step 1:** Bring wire behind thermometer and plug into bottom of thermometer being careful to insert it into the correct slots.



## Attaching the Dump Gate Handle

Your accessory kit includes a dump gate handle that needs to be screwed on to the rod protruding from the right side of the roaster. Secure this handle to the rod for easy bean dumping into the bean cooler.

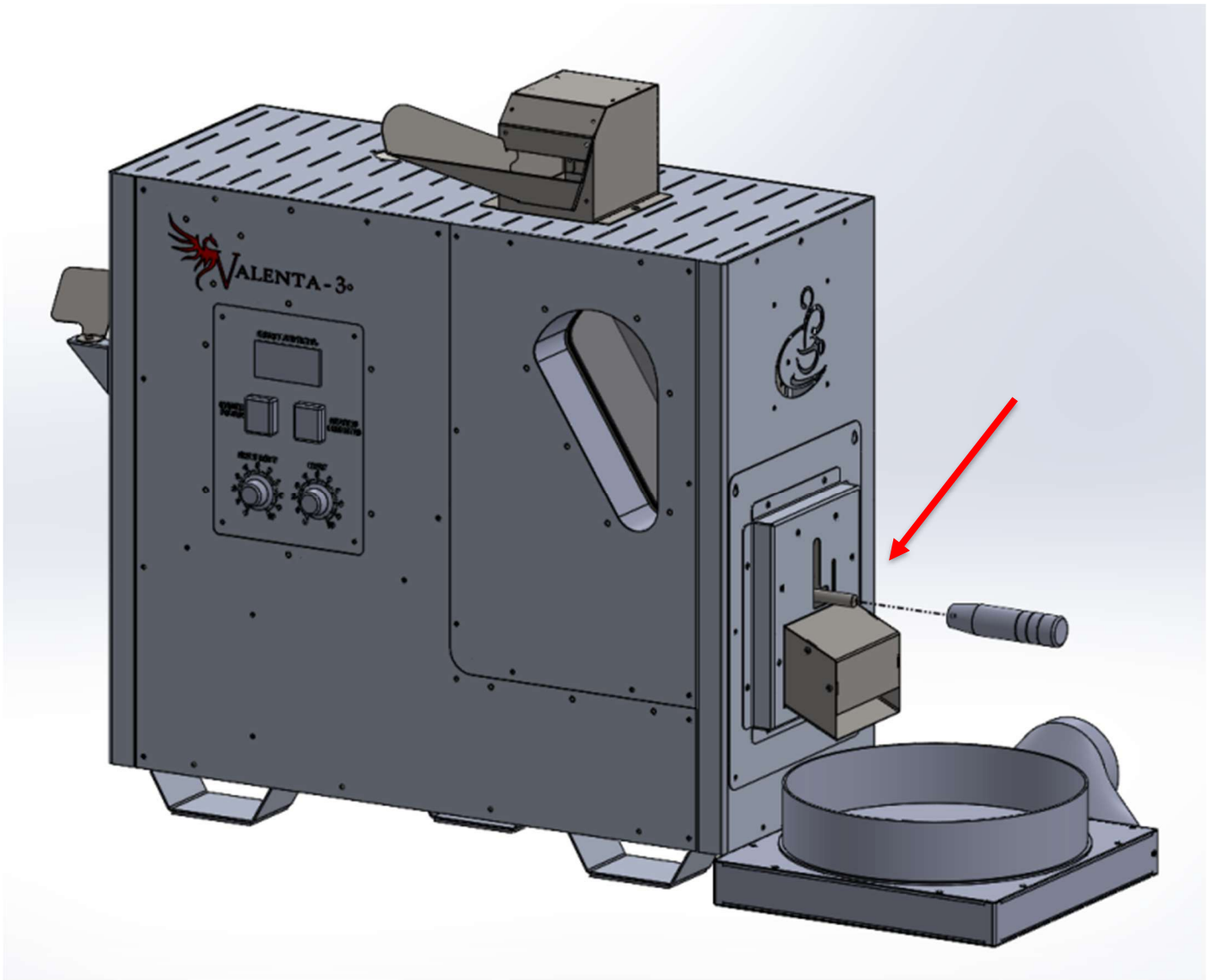

## INSTALLING CONDUIT AND CORD ROUTING

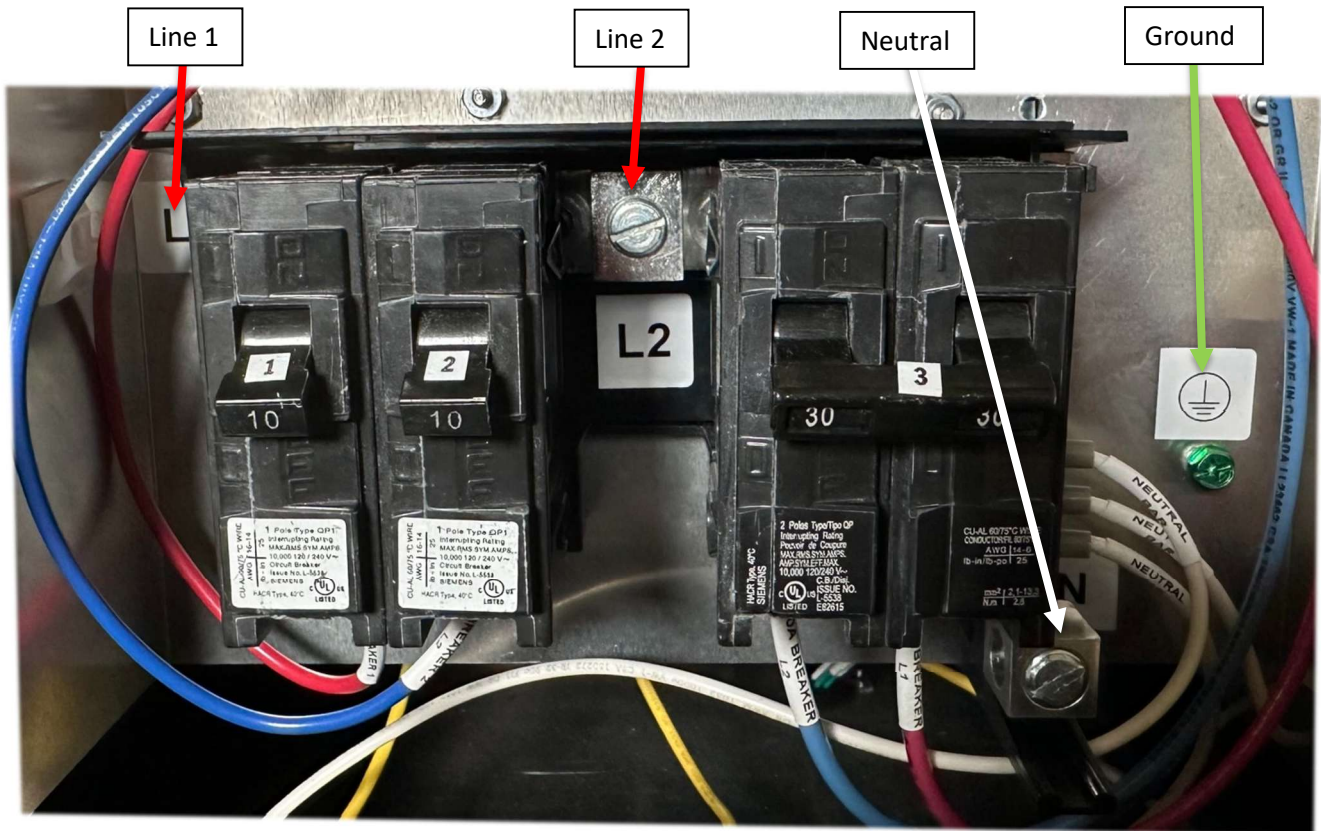

1. Install the electrical cord or rigid conduit to the power distribution block on the back of the roaster. For rigid conduit connection, remove the cord grip and install the proper conduit connector.

***Note: We recommend installing a pigtail and plug to ease in moving the roaster for cleaning. This roaster requires a 4-wire system with a ground for the hour meter to function properly.***

# INSTALLING EXHAUST BLOWER

Exhaust blower example : (BLOWER NOT PROVIDED WITH PURCHASE)

For this portion of the installation, the roaster is to be placed in its proper operating position.

1. Determine the direction your wye duct will be facing, we are showing it split, right and left for our set-up purposes. It can also face top to bottom.
2. Install the 4x4 metal wye duct to the blower motor. Slide the wye duct onto the motor. Use the self-tapping metal screw (provided) to secure the wye duct to the motor.

**Note: Your exhaust blower may have a 4", 5" or 6" intake. If you use a blower with a 5" or 6" intake, you will need the appropriate wye duct fitting to accommodate your roaster. Your roaster comes with a 4" wye duct fitting.**

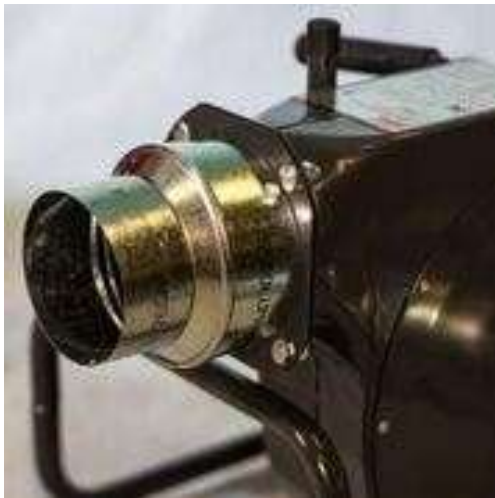

Discharge



Intake



## Flex Tubing

Here is a complete view of the tubing connected to the roaster, bean cooler and blower.

To connect the Flex Tubing you will need four (4) 4-inch hose clamps to complete the hook up.

1. Connect the Mast flex hose to one of the 4" wye duct openings.
2. Connect the Bean Cooling unit to one of the 4x4x4 wye ducts on the Blower Motor.

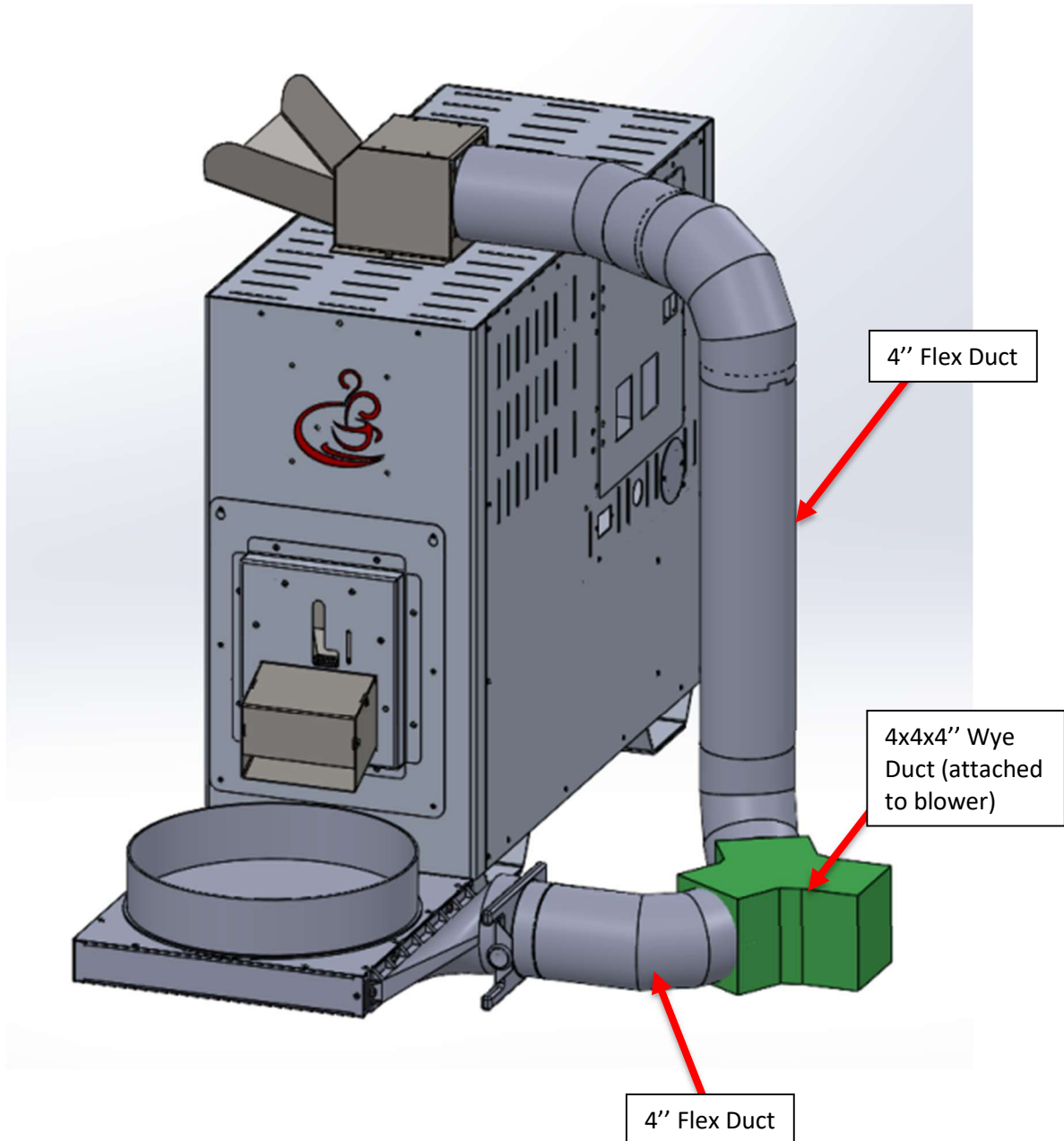

Depending on the floor plan you use, the tubing and wye ducting configuration may look different. Regardless of where you install the Blower, the origin and termination of each exhaust duct hook up will remain the same as shown in the Flex Tubing Diagram above.

## INSTALLING EXHAUST BLOWER CONTINUED

**NOTE:** Some installations may require longer runs to access a through wall fitting to the outside atmosphere. For longer runs please consult the outline below about lengths and deductions for elbows.

To reduce noise in the roasting area, install the exhaust blower under an insulated enclosure or on the other side of a wall. The exhaust blower motor is air cooled so make sure to not seal it completely without an intake air source.

### Recommended Duct Length with Elbows

- 4" exhaust duct runs should not exceed 80 feet. Deduct 5 feet for every 90-degree elbow in the run.
- 5" exhaust duct runs should not exceed 65 feet. Deduct 5 feet for every 90-degree elbow in the run.

### **Exhaust System**

Coffee Crafters recommends you use rigid ducting when connecting the blower exhaust discharge duct to the building through fitting. 4" or 5" rigid tubing is both acceptable. Make sure to **tape all duct joint seams from the exhaust discharge side of the blower** to avoid smoke escaping into your roasting area. This part of the system is pressurized and will leak smoke through open seams. For maximum run lengths, consult the above section of this manual for specific ventilation instructions.

**NOTE:** If you plan to exhaust using a 4" metal dryer ducting, a 5" to 4" reducer is provided.

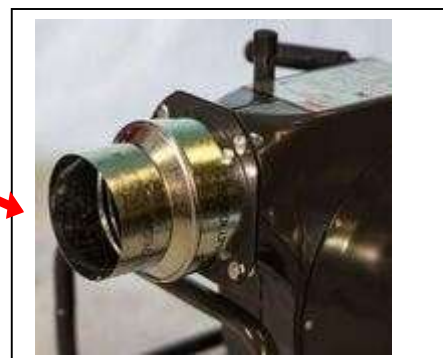

To minimize noise, your blower system may be placed in another room or under a cabinet. For maximum efficiency, the blower should be placed no more than 10 feet from the roaster.

## Chaff Bag Bracket Drawing

Below is the recommended installation of the chaff bag bracket. **Roaster exhaust must be vented to the outside.**

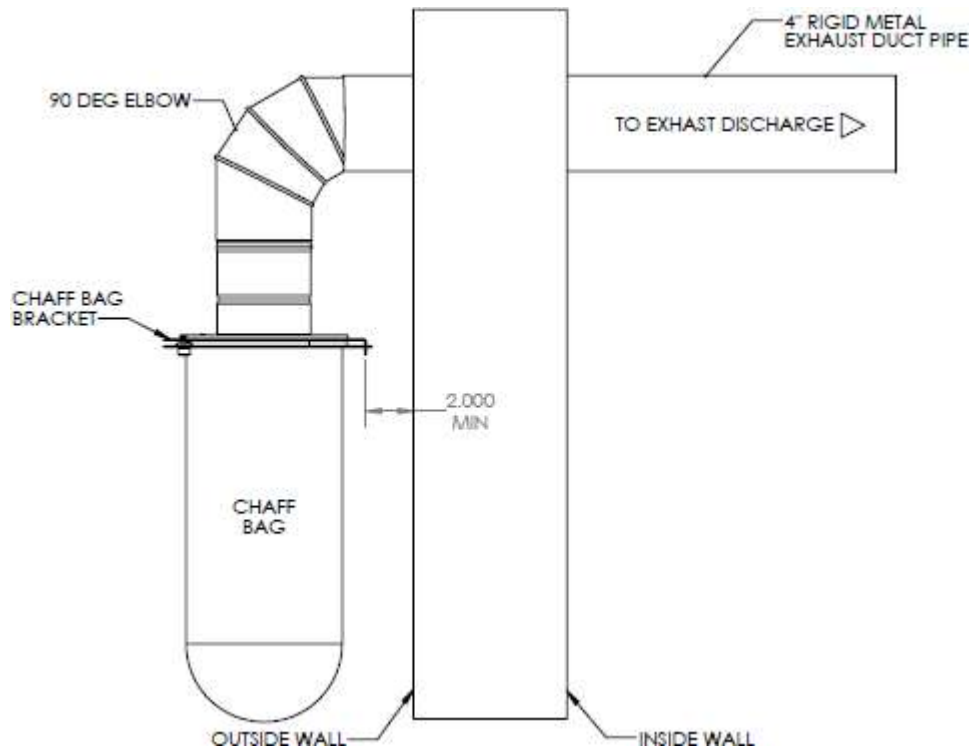

Your bracket comes with the chaff bag installed. To remove dirty chaff bag, loosen the two thumbscrews and remove the chaff bag.



## Ventilation Installation

The Valenta 3 roaster must be exhausted in accordance with the manufacturer's instructions as documented in the prior section of this manual. The roaster exhaust system must be independent of all other systems.

## Exhaust Penetrations

Any wall or ceiling penetration of ducts that transfer roaster exhaust must meet the International Building Code fire-resistance rating and cannot be located within any fire-blocking\* and/or draft-stopping\* areas. Unless such duct work is constructed of galvanized steel or aluminum of a thickness specified in Section 603.3 of the International Building Code and the fire-resistance rating is maintained.

\*Fire-blocking: Prevents movement of flame, smoke, gases through concealed spaces. Primarily addresses vertical movement.

\*Draft-stopping: Prevents movement of smoke and gases through concealed spaces. Primarily addresses horizontal movement.

## Cleanout

All ducting from the blower discharge to the outlet terminal must have a means for cleanout. Exhaust duct cleaning is required for all coffee roasting installations. Inspect exhaust tubing frequently. Clean or replace if excessive build up is present.

## Maximum Run Length

Maximum 5" diameter exhaust run shall not exceed 50' (feet) from the exhaust blower to the outlet terminal. For every 45° bend included in the exhaust duct path, 2 ½' (feet) must be deducted from the maximum of 50' duct work. For 90° bend included in the exhaust duct path, 5' must be deducted from the maximum of 50' duct work.

Example: There are two (2) 45° bends included in the exhaust duct path. The total maximum run length for a 5" exhaust duct is now 45' (feet).

## Blower Intake to Roaster Ducting

Flexible ducting is acceptable from the roaster/bean cooler to the exhaust blower intake. Flex ducting must be all metal. DO NOT USE plastic dryer ducting or aluminum flex duct with plastic liner.

## Blower Discharge Ducting

USE ONLY RIGID ducting from the blower discharge to the outlet terminal.

## Exhaust Gas Temperature

The exhaust gas temperature must not exceed 170° Fahrenheit (76.6° Celsius).

## Light Kit Installation

Take your light kit out of the box and remove the plastic sheath. Place the magnetic base on the designated spot on top of the roaster and direct the light beam overtop the loading chute and into the roasting chamber.

Position the light as shown below for optimum brightness inside the hopper. DO NOT put the light into the chute, this will cause the light to melt!

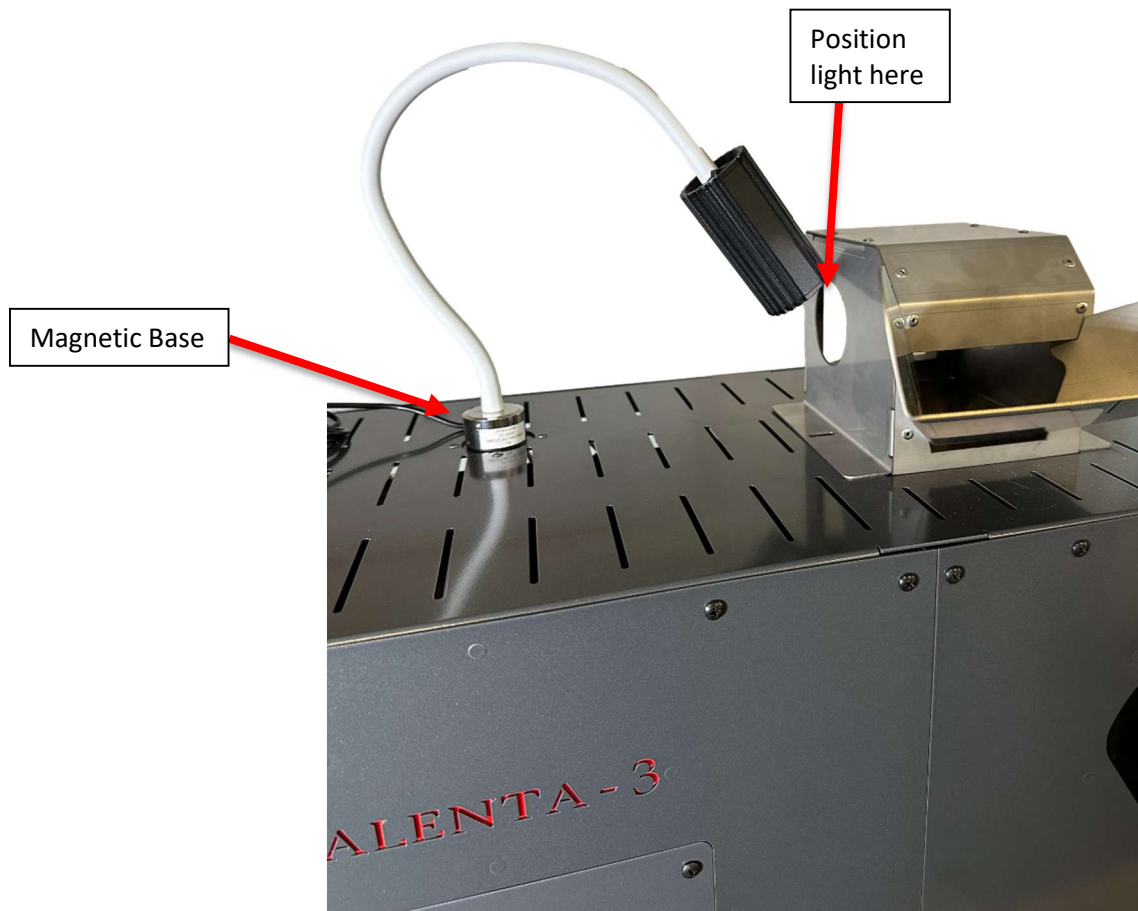

## Temperature Switch

The information contained here originated from the manufacturer, LOVE.

Bulletin E-90-TCS



### Series TCS Thermocouple Switch

### Specifications - Installation and Operating Instructions

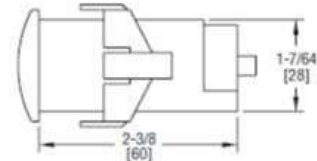
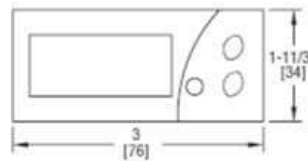

Monitor and control temperature in heating and cooling applications with the Series TCS Thermocouple Switch. The Series TCS offers a wide temperature range, two selectable alarm sets, and an internal buzzer indicating alarm condition or error. The user can define set point, heating/cooling regulation, cycle time, alarm configuration, load status, and ambient probe adjustment. The thermocouple switch features password protection and error/alarm messaging. Temperature and output status is indicated on the bright red LED display. Use the configuration key (sold separately) to quickly program multiple units. The Series TCS includes a fitting clip for panel mounting, gasket, rear terminal cover and instruction manual.

#### INSTALLATION

**Note:** Unit must be mounted away from vibration, impacts, water and corrosive gases.

- Cut hole in panel 2.80 x 1.14 inches (71 x 29 mm).
- Apply silicone (or rubber gasket) around the perimeter of the hole to prevent leakage.
- Insert unit into hole of panel.
- Slide removable fitting clips onto unit from the back until secure to panel.
- Remove back cover to wire unit.
- Wiring diagram is displayed on the top of the unit.
- (Note: PROBE CABLE LENGTH MUST NOT EXCEED 238 ft (100 m). DO NOT INSTALL PROBE CABLE NEAR POWER CABLES).
- Replace cover once wiring is complete.

#### SPECIFICATIONS

**Probe Range:** 32 to 999°F (0 to 700°C) for Type J thermocouple; 32 to 999°F (0 to 999°C) for Type K or S thermocouples.

**Input:** Type J, K or S thermocouple.

**Output:** SPDT relay rated 16A @ 240 VAC resistive.

**Horsepower Rating (HP):** 1 HP.

**Control Type:** ON/OFF.

**Power Requirements:** 115 VAC, 230 VAC, 12 VAC/VDC or 24 VAC/VDC (depending on model).

**Accuracy:** ±1% FS.

**Display:** 3-digit, red, 1/2" (12.7 mm) digits, plus sign.

**Resolution:** 1°.

**Memory Backup:** Nonvolatile memory.

**Temperature Limits:**

Ambient: 32 to 158°F (0 to 70°C);

Storage Temperature: -4 to 176°F (-20 to 80°C).

**Weight:** 2.3 oz (65 g).

**Front Panel Rating:** IP64.

**Agency Approvals:** CE, cUR, UR.

#### WIRING DIAGRAM

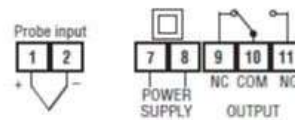

©Copyright 2014 Dwyer Instruments, Inc.

Printed in U.S.A. 2/14

FR# R0-443801-00 Rev.1

**LOVE CONTROLS DIVISION**  
**DWYER INSTRUMENTS INC.**  
 P.O. BOX 338 - MICHIGAN CITY, INDIANA 46360, U.S.A.

Phone: 219/879-8000 [www.love-controls.com](http://www.love-controls.com)  
 Fax: 219/872-9057 e-mail: [love@love-controls.com](mailto:love@love-controls.com)

## Helpful Tips

1. Go to the Maintenance and Troubleshooting section for instructions on proper cleaning of the Valenta 3 Roaster.
2. Your roaster does not require preheating.
3. Visit our website for roasting tips, the green bean distributor map, and more!



[www.coffecrafters.com](http://www.coffecrafters.com)

You are now ready to roast coffee. Proceed to the next section of this manual for initial testing and roasting instructions.

# Roasting

Before roasting your first batch of coffee it's important to orient yourself with proper safety procedures. Treat your roaster the same as you would a cook top range. During the roast your roast hopper viewing ports get as hot as any pot on your stove. The air that roasts your coffee reaches temperatures over 500° degrees F.

## Roast Coffee in 6 easy steps:

1. Check the Chaff bag
2. Turn on Exhaust Blower
3. Turn on System Power Switch
4. Set Bean Loft
5. Load Beans into the hopper through the hood with the bean loader
6. Turn on heating element

### Step 1: Check the Chaff Bag

Ensure the chaff bag is secured in place and less than 50% full before roasting.

### Step 2: Turn on Exhaust Blower

Never run your roaster without the chaff/exhaust blower running. The blower keeps the machine cool and prevents chaff, smoke, and heat from venting into your roast area.

The on/off switch is located on the front or side of the blower motor. This directs all the suction through the hood, so chaff does not escape.

Your blower may look different than the one shown in the picture depending on which blower you purchase.

**If this is your first roast of the day, preheat your Valenta 3 Roaster before you start roasting by turning on the loft to 3 and heat to 10 until you see the roast air temperature reads 400 degrees F (usually 1 minute).**

### Step 3: Turn on System Power Switch

The system power switch is the single red switch to the left. As a safety feature the heat elements cannot be turned on with the system power switch in the off position.



## Step 4: Set the Bean Loft

The bean loft blower knob is marked low to high. **Remember; never load the beans into the hopper until you have established the loft!** This prevents beans from being burned in the hopper (especially every roast after your first roast of the day as the heating elements will still be very hot). Slowly turn up the air by turning the knob clockwise. Practice this several times before turning on the heat to familiarize yourself with the feel of lofting beans.

Set the bean loft according to the recommended setting on page 28. Please note: You will set the loft at a slightly higher setting while loading the beans and then turn it down slightly while roasting. This is a safety precaution because the beans will burn very quickly if they are not moving the entire time they are in the hopper. Once the beans are in the hopper, you will turn down the loft slightly so the beans can settle into their roasting cycle.

### CAUTION:

Never let the beans stop lofting with the heat elements on. You will burn your beans and possibly damage your Roaster.

Airflow simulation →

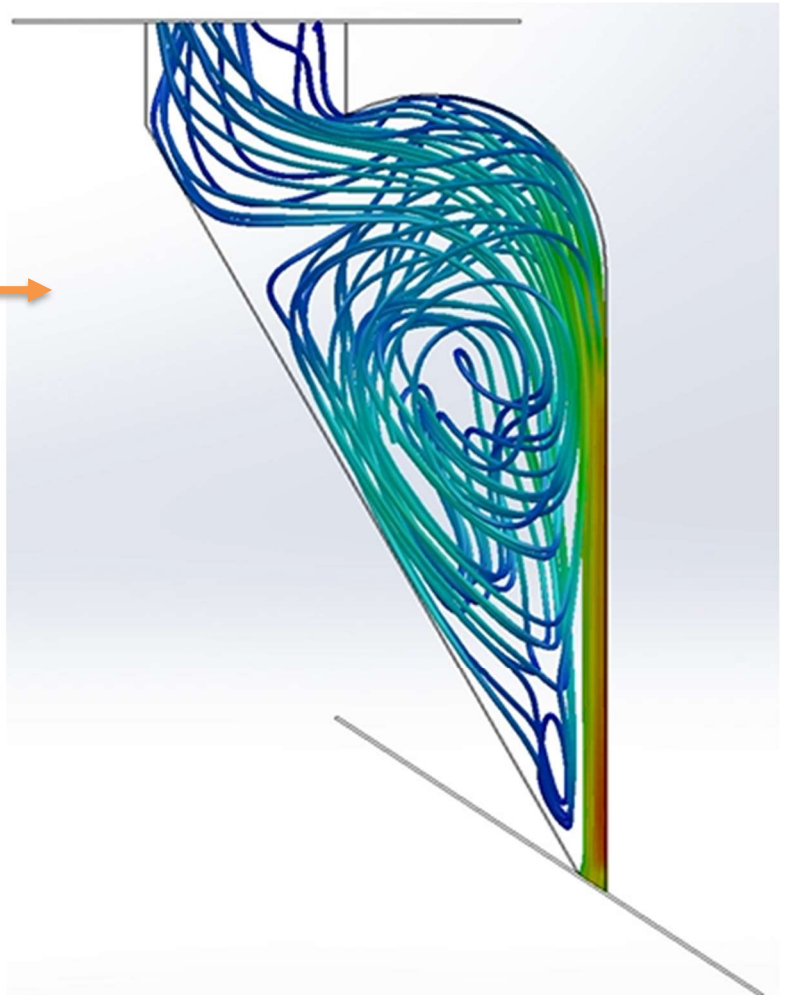

## Step 5: Load Beans in Top Hopper

Make sure your air loft adjustment is ON prior to pouring in the beans.

Load the beans into bean hopper by pouring the beans down the loading chute. We recommend using a food grade bucket or the provided coffee scoop for the pouring process that will hold 3 lbs. of green beans.



## Step 6: Turn on Heating Element

1. Turn on the heating elements switch.
2. Use the heat adjustment knob (measured from 1 to 10) below the Temperature Controller to set the heat for your batch size.
3. Re-adjust your bean loft if needed-sometimes the loft decreases after the heat switch is turned on.

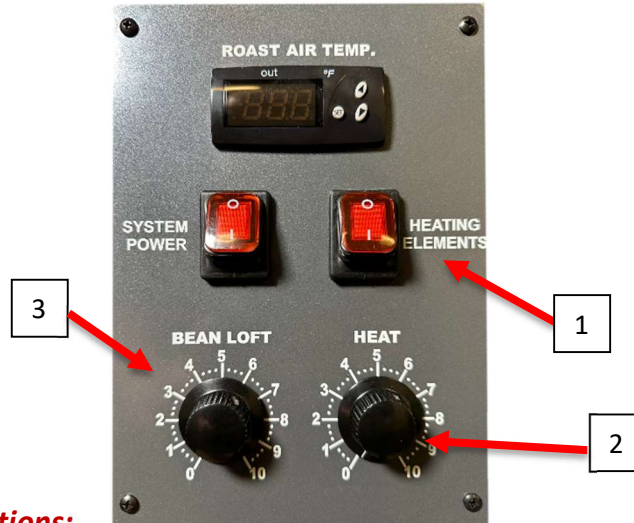

### Roasting Recommendations:

BATCH SIZE IN LBS	Loading Loft	Roasting Loft	HEAT SETTING
1	3	2.75	6
2	3.5	3	7
3	4	3.5	9.5

**NOTE:** These are only recommendations and may vary based on altitude, humidity, line voltage and ambient air temperature. Roast times will vary based on loft and heat settings. If you average 8-minute roast times, you will be able to roast 21 lbs. per hour.

You can increase or decrease the heat setting to achieve the temperature you need.

Roasting times may vary due to room temperature, or if machine is warm or cold. Always monitor the batch while roasting, NEVER leave unattended and watch the bean temperature to achieve the desired roast. You will quickly learn which settings work best for your roasting style.

If roasting below a 200-grams batch, the bean temperature may not read accurately.

Roasting on the Valenta 3 is very easy. Never leave your roaster unattended. If you lose your bean loft you will ruin your batch and possibly damage your Roaster. Coffee beans will catch on fire if they stop circulating!

## Roasting Complete: Cool the Beans

Coffee beans must be cooled quickly after you reach your desired bean temperature. You can see into the hopper as the roast progresses, but a good rule of thumb is to stop your roast a few degrees before you reach your desired temperature. With the light shining in the hopper, the beans look lighter than they do when removed from the hopper.

1. Open the bean cooler blast gate.
2. Turn off the Heat element switch.
3. Turn off the loft.
4. Lift the dump gate and let the beans fall into the bean cooling tray.

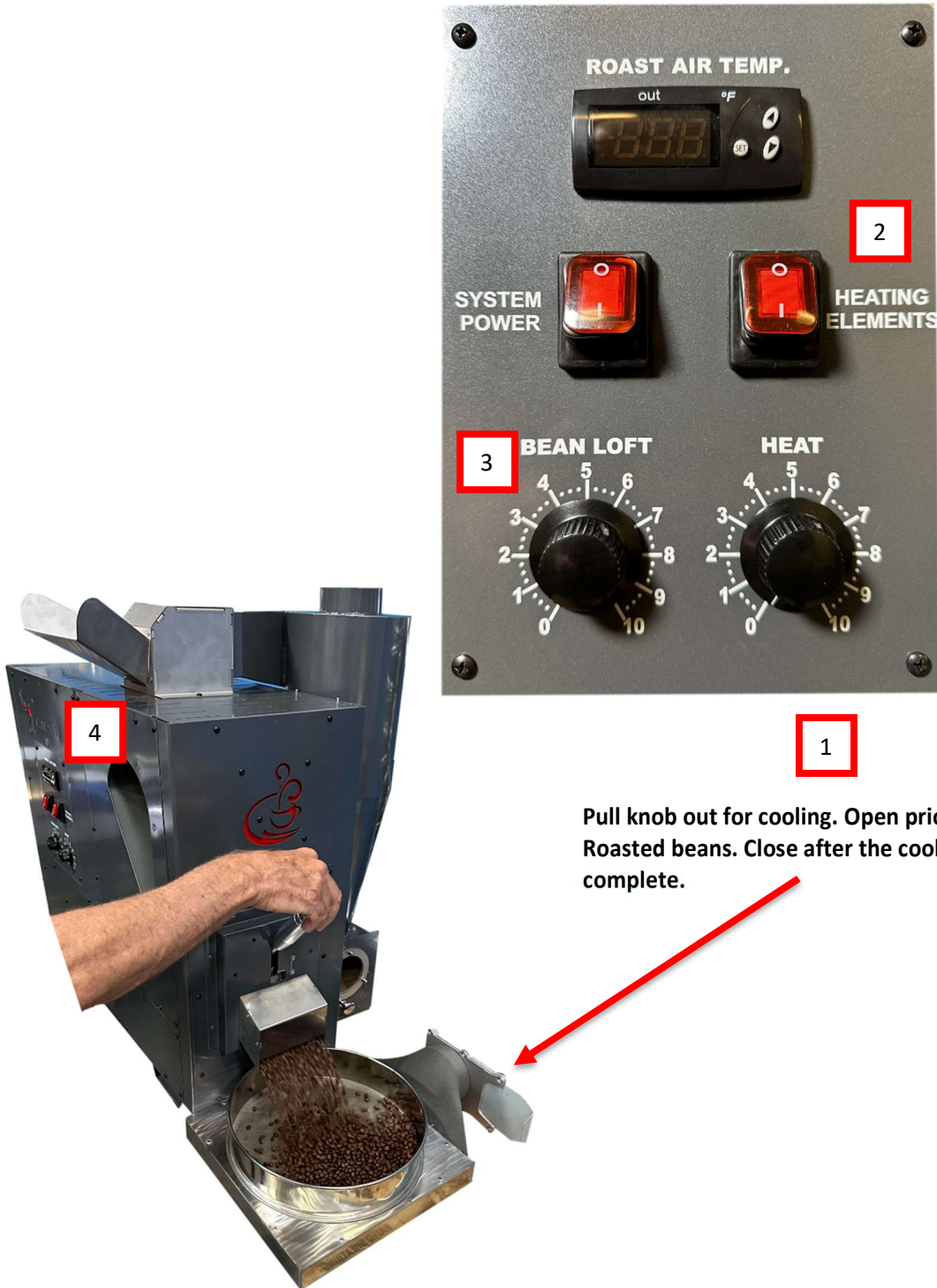

With the beans in the cooling tray, stir the beans occasionally with a stainless-steel spoon to make sure there are no hot spots. As you stir your beans, this is a good time to check for any rocks or foreign objects. Cooling takes about 1 minute for smaller loads and about 1 ½ minutes for larger loads.

After your beans are sufficiently cooled down, return the cooling knob to its original position closing the air tube under the tray. Our tray is designed to be removed for easy pouring of roasted beans.



# Coffee Bean Education

## Proper Storage of Green Coffee Beans

The two most important variables for storing your beans are humidity and temperature.

Your green beans will keep for over 2 years when stored properly.

Some good tips to keep in mind:

- Store beans between 50-85° F (If the temperature is comfortable for you, it's comfortable for your beans)
- If you purchased full bags, keep beans in jute bag they came in for good breathability
- Keep your beans off the ground (wood pallets work best). This helps promote allaround air circulation and prevents condensation
- Keep away from pets
- Place beans away from sink and water sources

Things to avoid:

- High humidity
- Changes in temperature
- Direct sunlight

If you are purchasing smaller quantities and don't plan on storing your beans for long periods of time, storing your beans in food grade buckets will work well. These Gamma screw lids give an airtight seal and are easy to open/close (available on Amazon).



Another great, but expensive, storage option is to keep beans in vacuum sealed bags. Vacuum packed beans do not need to be monitored as much since they are not exposed to oxygen and atmospheric moisture.

## Green Coffee Bean Abbreviations and Meanings

**SSFC** – Strictly Soft Fine Cup – Grown at relatively low altitudes (under 1200 meters). These beans mature quickly and produce a lighter, less dense bean. This term also means the beans are free of hard riyoy taints. Fine cup means it is a specialty grade coffee.

**RFA** – Rain Forest Alliance – Meets the standards that are intended to protect the environment and the rights of workers.

**FTO** – Fair Trade Organic – Certified as a fair-trade bean with Organic classification.

**FT** – Fair Trade – Certified as a fair-trade bean.

**EP** – European Preparation – These beans are hand sorted to remove any defective beans and foreign material.

**SHB** – Strictly Hard Beans – Grown at an altitude above 1350 meters.

**SWP** – Swiss Water Process – Decaffeinating process that includes a “flavor charged” water. 100% chemical free.

**MWP** – Mountain Water Process – Decaffeinating process that results in flavorful beans that are 99.9% caffeine free.

**MC** – Methylene Chloride – Used to decaffeinate coffee and some believe it to maintain coffee flavor better than other processes.

**EA** – Ethyl Acetate – An ester found naturally in fruits and vegetables that is used to decaffeinate coffee.

**SHG** – Strictly High Grown – This classification is higher than HB (Hard bean).

**AA** – Reference to a 17/18 screen size.

**AB** – Refers to size. AB consists of both A and B coffee beans; screen sizes 15 and 16. AB are small than AA and not as valued.

**Fancy** – Refers to better quality than average specialty quality for Arabica beans.

**17/18** – Refers to screen size. The larger bean size generally correlates to a higher quality bean.

**Rioy Taints** – Defect in the bean resulted from an over ripened cherry.

**Quaker** – Defect in bean. Unripe cherry.

# Maintenance and Troubleshooting

## Maintenance

Your Roaster requires periodic maintenance and cleaning. Maintenance and cleaning will be dependent on the amount of coffee you roast.

## Chaff Bags

Every time you roast, inspect the condition of the chaff bag. The suction works best when the bag is less than half full and clean. Empty your bag often. When the bag becomes covered in excess chaff dust, replace with a clean bag. Dirty Chaff bags can be washed with a mild detergent and air dried completely to use again.

Inside the Chaff Collector unit can be vacuumed after the chaff bag is removed for cleaning.



## Roast Hopper Cleaning

Please refer to our YouTube video on removing and cleaning the hopper:



## Bean Cooling Tray

With use, especially with darker roasts, you will notice a buildup of oils inside your cooling tray. Remove the tray and wash with warm soapy water, rinsing and drying well. When the tray is removed from the cooling unit, take this time to clean out any beans that have fallen into the cooling void under the tray. A vacuum will remove the dust and beans then you can wipe out this area with a damp cloth.

## Mast Tubing Maintenance

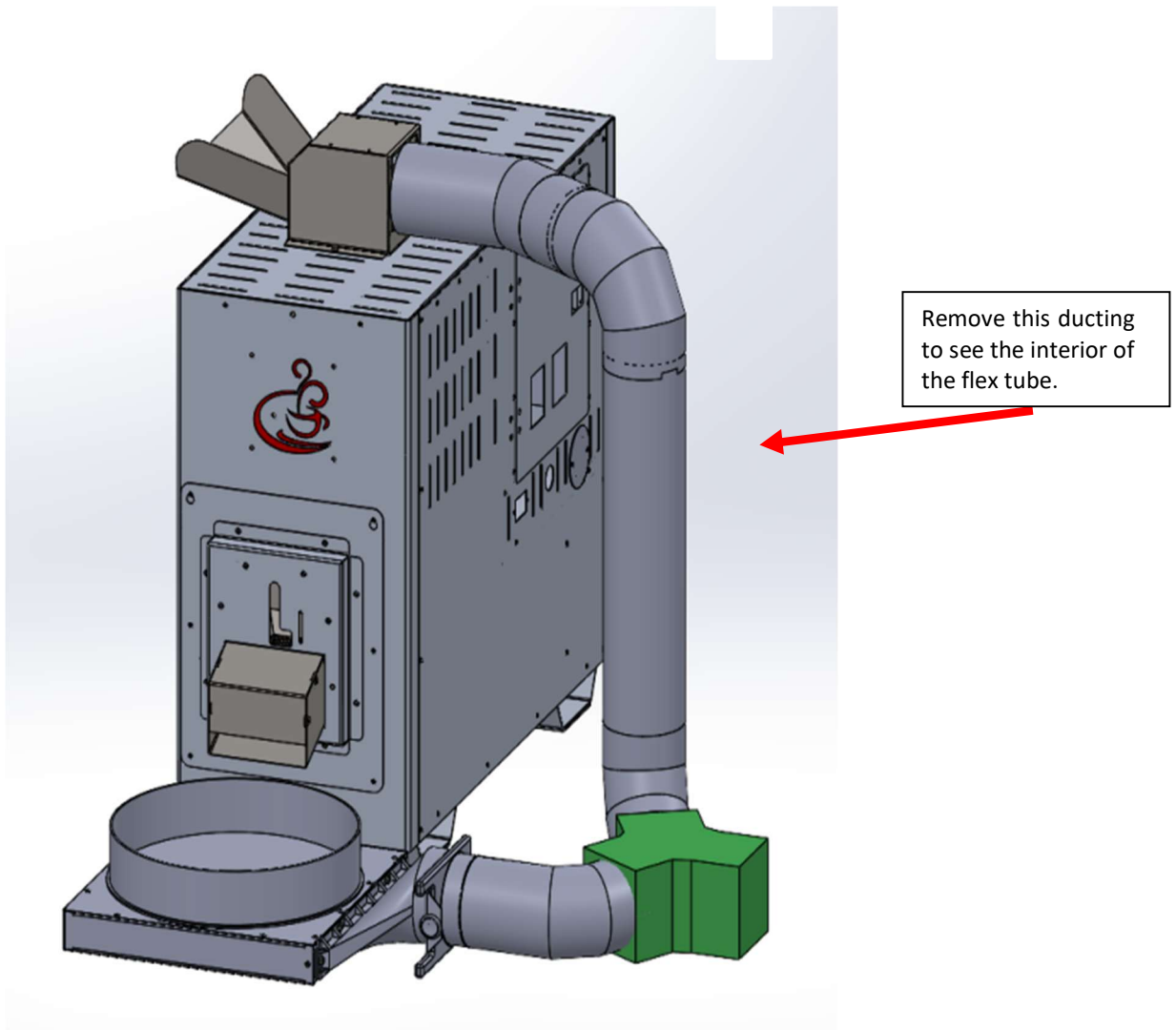

Replace Mast Flex Ducting when dirty. This can be checked by removing the duct on the upper chaff collector as indicated in the image above. When you can no longer see metal inside the ducting, it is time to clean it.

Please note, this image is used to show how the exhaust blower is hooked up to the roaster but the blower can be moved to either side of the roaster as you see fit.

## Exhaust Tubing

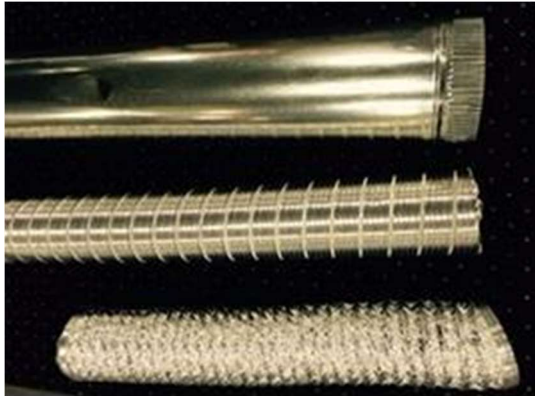

← Rigid Tubing

← Semi-Rigid Flex Tubing

← Flexible Tubing

**\*\*IMPORTANT- Make sure to unplug the blower before attempting any of the following steps\*\***

You will need to access the inside of the solid exhaust tubing to be able to run a brush down the inside of the tubing. If you have elbows in your exhaust tube line, you may have to take apart your line to fully clean the exhaust tubes.

After the solid tubing is cleaned, inspect the inside of your blower prior to reinstalling the tubing. Take a brush and go over each fin on the inside of the blower. Once everything is reattached, turning on the blower will remove the debris. (See YouTube video on blower cleaning)

Depending on how many pounds (lbs.) of beans you roast daily will determine how often you change the flexible tubing. The buildup of chaff dust can present a fire hazard. When the inside of the tubing is completely covered with dust, it is a good time to replace it. (See YouTube video on venting)

## Exterior Surfaces

It is sufficient to clean the lid by wiping down its surface with a damp cloth. Never use an overly wet towel to clean the lid. Any excess liquid could damage electrical components.

The body of the Roaster can be washed down with a damp cloth or mild detergent. Do not use industrial spray cleaners/degreasers on your roaster.

## Troubleshooting

This portion of the manual is intended to provide guidance for roaster owners and qualified repair persons working on the Valenta 3.

Mechanical and operational issues most commonly experienced by customers are addressed. The Valenta 3 has proven to be a very reliable machine but like all mechanical devices, things will go wrong.

Coffee Crafters roasters were designed from the ground up to be very easy to operate and maintain. All wiring is color coded and labeled. Additionally, videos are available on changing most of the machine components.

Coffee Crafters maintains a full inventory of replacement parts. Please refer to the Parts List section of this manual when ordering. Your machine serial number can be found on the top of the power distribution block on the back of your machine. Please include your machine serial number when making inquiries about your machine. Coffee Crafters maintains a history of your machine accessible with your machine serial number.

Problem	Cause(s)	Solution
Exhaust blower starts to lose suction	<ol style="list-style-type: none"><li>1. The chaff bag is dirty.</li><li>2. An obstruction in the vent pipe.</li><li>3. The bean cooler blast gate is open.</li></ol>	<ol style="list-style-type: none"><li>1. Replace the dirty chaff bag with a clean one.</li><li>2. Check the vent pipe from the blower discharge through the through wall fitting. Remove obstruction or replace damaged duct pipe.</li><li>3. Close the bean cooler blast gate while roasting.</li></ol> <p>Note: The most common cause for a loss in exhaust suction is a dirty chaff filter bag. The bag will plug much faster with darker roasts which produces oily residue captured by the bag.</p> <p>The filter bags are machine washable. Check filter bags often and replace when dirty.</p> <p>Clean filter bags reduce exhaust temperature and keep your machine running smoothly.</p>

Problem	Cause(s)	Solution
Bean Loft motor won't start.	<ol style="list-style-type: none"> <li>1. System power switch is in the "off" position.</li> <li>2. Faulty system power switch.</li> <li>3. SSR-1 has failed.</li> <li>4. Faulty potentiometer.</li> <li>5. Tripped system power fuse.</li> </ol>	<ol style="list-style-type: none"> <li>1. Ensure system power switch is in the "on" position.</li> <li>2. Check system power switch voltage when in the 'on' position. If no voltage, replace switch.</li> <li>3. Check SSR-1 voltage output. If there is no voltage output, replace SSR-1.</li> <li>4. Check motor speed control potentiometer for linear resistance. If ohms of resistance do not reduce to "0" when potentiometer is turned all the way up, replace potentiometer.</li> <li>5. Check for tripped system power fuse located on the back of the machine.</li> </ol> <p>Note: A tripped system power fuse is an indication that a fault has occurred in the system.</p> <p>If by resetting the fuse, it does not come on, call the manufacturer.</p>

<b>Problem</b>	<b>Cause(s)</b>	<b>Solution</b>
Bean Loft motor powers up but elements won't turn on.	<ol style="list-style-type: none"> <li>1. Heat element switch failed.</li> <li>2. Faulty connector on input side of heat switch.</li> <li>3. Temperature controller setting.</li> <li>4. Faulty temperature controller.</li> </ol>	<ol style="list-style-type: none"> <li>1. Replace heat element switch.</li> <li>2. Replace connector and heat switch.</li> <li>3. Check the roast air temperature control setting. Roast air temperature must be set higher than your desired ending bean temperature.</li> <li>4. Replace temperature controller.</li> </ol> <p>Note: The system power switch supplies power to the input of the heat switches when in the "on" position. If the heat elements do not come on when the heat switch is turned "on", check the voltage on the output of the heat switch (center terminal). If no voltage, replace switch.</p>

<b>Problem</b>	<b>Cause(s)</b>	<b>Solution</b>
Speed control knob will not reduce bean loft motor RPM.	<ol style="list-style-type: none"> <li>1. SSR-1 has failed.</li> <li>2. Motor speed control potentiometer has failed.</li> </ol>	<ol style="list-style-type: none"> <li>1. Replace SSR-1.</li> <li>2. Replace motor speed control potentiometer.</li> </ol>

Problem	Cause(s)	Solution
Elements running but roaststake too long.	<ol style="list-style-type: none"> <li data-bbox="412 266 755 331">1. Ambient air temperature is too low.</li> <li data-bbox="412 373 651 401">2. Low line voltage.</li> </ol>	<ol style="list-style-type: none"> <li data-bbox="784 266 1419 365">1. Roast smaller loads until you identify maximum load size where machine can reach optimum roast air temperature.</li> <li data-bbox="784 443 1195 470">2. Install a buck boost transformer.</li> </ol> <p data-bbox="784 516 1446 615">Note: Roasting in cold environments below 50° Fahrenheit will increase roast times. We suggest roasting in an enclosed, heated environment in cold weather.</p> <p data-bbox="784 657 1430 827">The roaster does not perform well below 235-line voltage under load. If you confirm that both heat elements are running but have trouble achieving your desired roast air temperature with full loads, have a qualified electrician check your line voltage under load.</p>
Air coming out of Dump Gate.	<ol style="list-style-type: none"> <li data-bbox="412 871 662 936">1. Dump gate needs adjusting.</li> </ol>	<ol style="list-style-type: none"> <li data-bbox="784 871 1219 936">1. See video on adjusting Dump Gate (Insert QR code to video)</li> </ol>

## Troubleshooting Figure 1.1

Electricals with back panel removed.

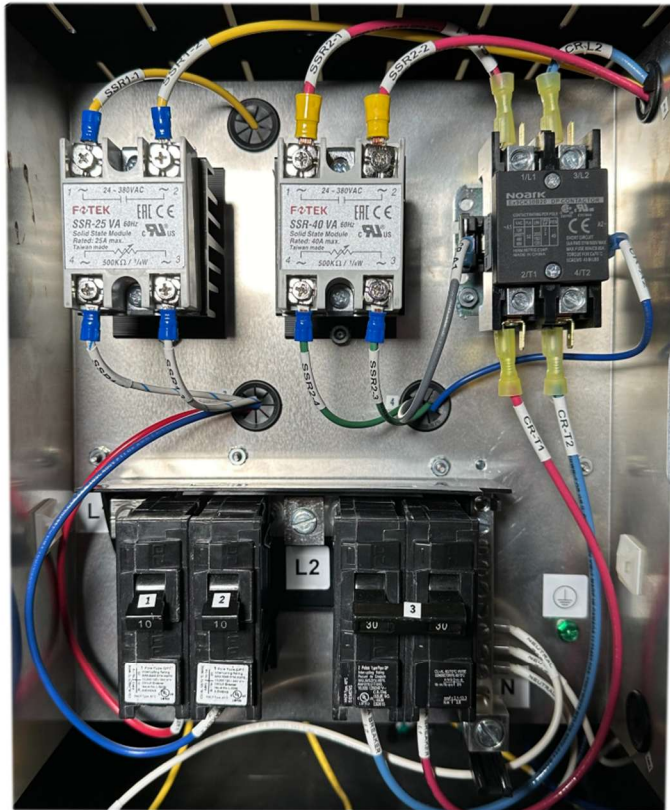

Wiring connection of controllers underneath the lid.



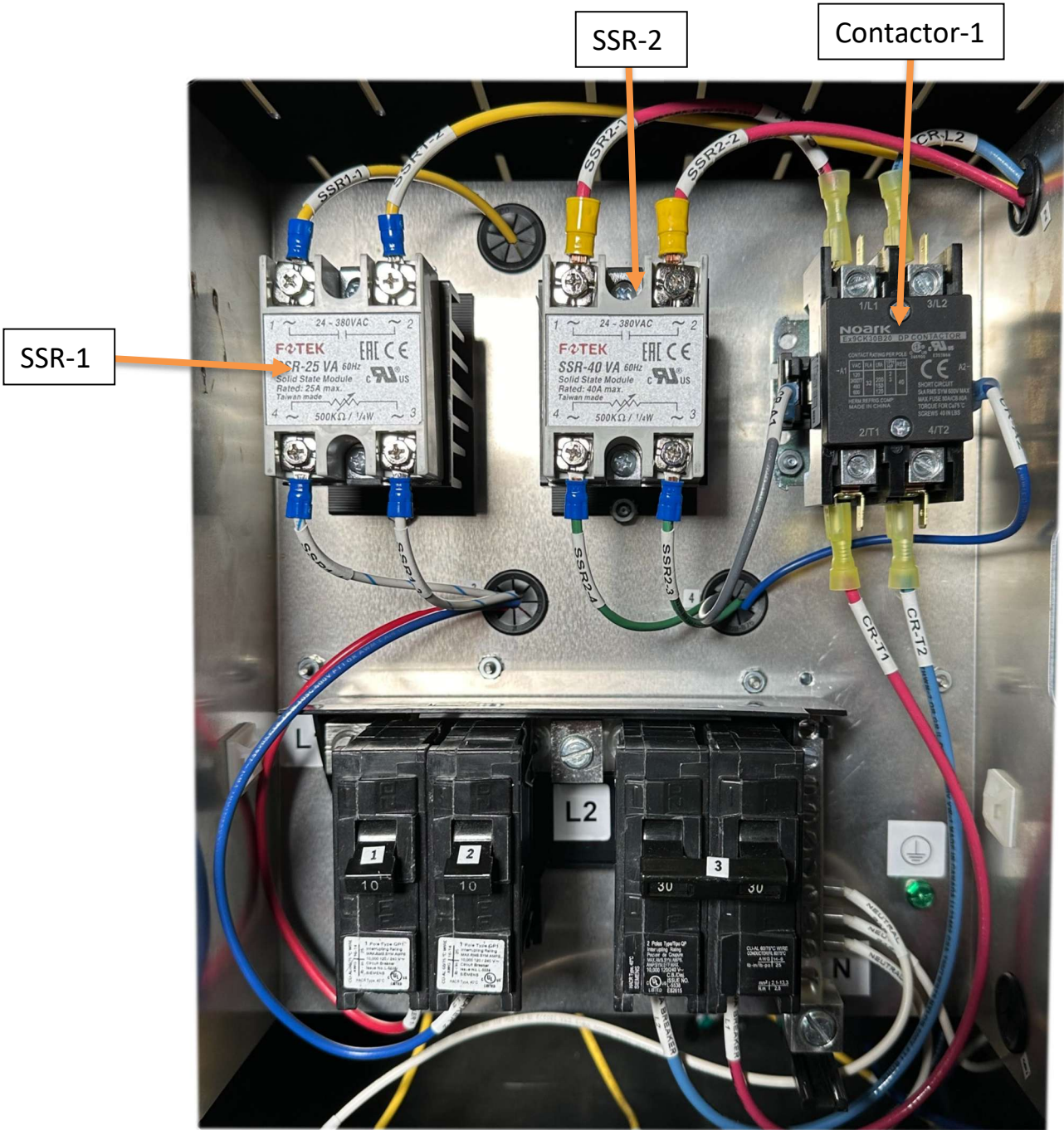

Note that the SSR's are installed with the writing upside down. Potentiometer connections are on the top, power connections are on the bottom.



← **SSR 1**  
**Motor Speed Control Module**



← **SSR 2**  
**Heat Control Module**



**Noark Contactor**

# USA Wiring Diagram

## Coffee Crafters



### VALENTA 3 ROASTER WIRE DIAGRAM REV. A AMERICAN 240 VAC, 60 HZ

FIELD WIRING	
CORNER & IFC ON DISPLAY	VALENTA 3
WIRE CURRENT RATING: 40 AMP	MAX VOLTAGE: 240V AC
PROTECTION: 40 AMP @ 600 VAC	CURRENT RATING: 40 AMP
TIGHTENING TORQUE: 45 IN. LB.	PROTECT SINGLE
	FREQUENTLY SERVICE
	P.L.V. 233 A
	FLC: 233 A
	SCOP: 2000 & 2000 AC
	USE FIELD & EXCESS
	CONNECTIONS TO BE MADE
	CONFORM TO VALENTA 3 ROASTER

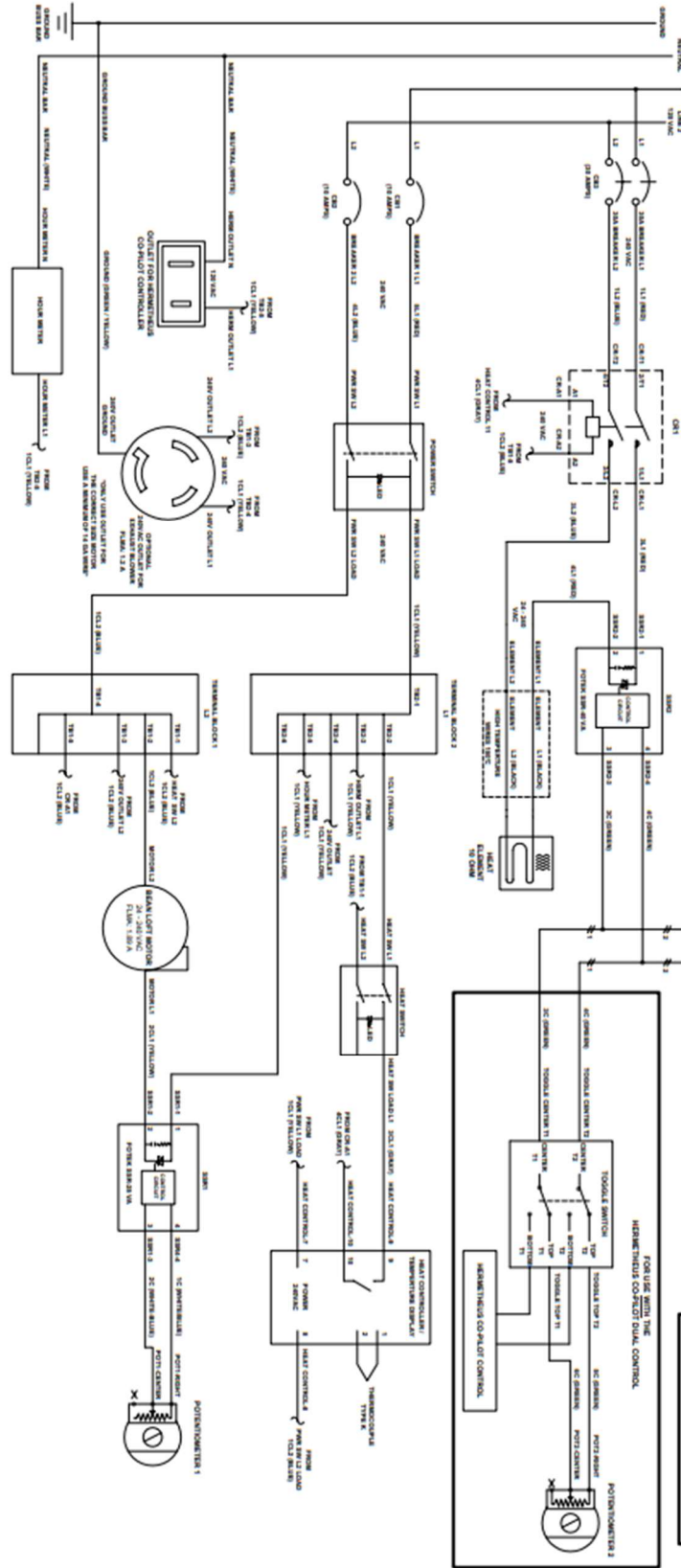

NOTE:  
WIRING MARKED WITH 'N1' ARE FOR A VALENTA 3  
HEATERS CONTROL CO-PILOT DUAL CONTROL.  
WIRING MARKED WITH 'N2' ARE FOR A VALENTA 3  
HEATERS CONTROL CO-PILOT DUAL CONTROL.

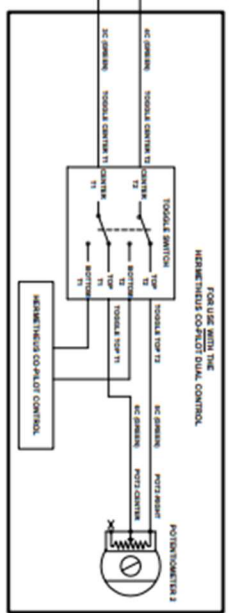
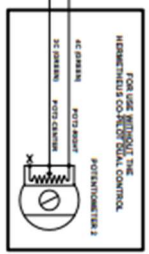

3	WIRING IS FOR EUROPE/UK/US/AUSTRALIA 230VAC, 50HZ	08/29/24	NL
A	WIRING IS FOR AMERICAN 240VAC, 60HZ	09/29/24	NY
REV.	REVISION	DATE	APPROVED



TITLE: COFFEE CRAFTERS VALENTA 3 ROASTER WIRE DIAGRAM		REVISIONS NO. REV. DATE BY	
1	08/29/24	NL	VALENTA 3 ROASTER WIRE DIAGRAM
2	09/29/24	NY	REVISIONS
3	09/29/24	NY	REVISIONS
4	09/29/24	NY	REVISIONS
5	09/29/24	NY	REVISIONS
6	09/29/24	NY	REVISIONS
7	09/29/24	NY	REVISIONS
8	09/29/24	NY	REVISIONS
9	09/29/24	NY	REVISIONS
10	09/29/24	NY	REVISIONS
11	09/29/24	NY	REVISIONS
12	09/29/24	NY	REVISIONS
13	09/29/24	NY	REVISIONS
14	09/29/24	NY	REVISIONS
15	09/29/24	NY	REVISIONS
16	09/29/24	NY	REVISIONS
17	09/29/24	NY	REVISIONS
18	09/29/24	NY	REVISIONS
19	09/29/24	NY	REVISIONS
20	09/29/24	NY	REVISIONS
21	09/29/24	NY	REVISIONS
22	09/29/24	NY	REVISIONS
23	09/29/24	NY	REVISIONS
24	09/29/24	NY	REVISIONS
25	09/29/24	NY	REVISIONS
26	09/29/24	NY	REVISIONS
27	09/29/24	NY	REVISIONS
28	09/29/24	NY	REVISIONS
29	09/29/24	NY	REVISIONS
30	09/29/24	NY	REVISIONS
31	09/29/24	NY	REVISIONS
32	09/29/24	NY	REVISIONS
33	09/29/24	NY	REVISIONS
34	09/29/24	NY	REVISIONS
35	09/29/24	NY	REVISIONS
36	09/29/24	NY	REVISIONS
37	09/29/24	NY	REVISIONS
38	09/29/24	NY	REVISIONS
39	09/29/24	NY	REVISIONS
40	09/29/24	NY	REVISIONS
41	09/29/24	NY	REVISIONS
42	09/29/24	NY	REVISIONS
43	09/29/24	NY	REVISIONS
44	09/29/24	NY	REVISIONS
45	09/29/24	NY	REVISIONS
46	09/29/24	NY	REVISIONS
47	09/29/24	NY	REVISIONS
48	09/29/24	NY	REVISIONS
49	09/29/24	NY	REVISIONS
50	09/29/24	NY	REVISIONS
51	09/29/24	NY	REVISIONS
52	09/29/24	NY	REVISIONS
53	09/29/24	NY	REVISIONS
54	09/29/24	NY	REVISIONS
55	09/29/24	NY	REVISIONS
56	09/29/24	NY	REVISIONS
57	09/29/24	NY	REVISIONS
58	09/29/24	NY	REVISIONS
59	09/29/24	NY	REVISIONS
60	09/29/24	NY	REVISIONS
61	09/29/24	NY	REVISIONS
62	09/29/24	NY	REVISIONS
63	09/29/24	NY	REVISIONS
64	09/29/24	NY	REVISIONS
65	09/29/24	NY	REVISIONS
66	09/29/24	NY	REVISIONS
67	09/29/24	NY	REVISIONS
68	09/29/24	NY	REVISIONS
69	09/29/24	NY	REVISIONS
70	09/29/24	NY	REVISIONS
71	09/29/24	NY	REVISIONS
72	09/29/24	NY	REVISIONS
73	09/29/24	NY	REVISIONS
74	09/29/24	NY	REVISIONS
75	09/29/24	NY	REVISIONS
76	09/29/24	NY	REVISIONS
77	09/29/24	NY	REVISIONS
78	09/29/24	NY	REVISIONS
79	09/29/24	NY	REVISIONS
80	09/29/24	NY	REVISIONS
81	09/29/24	NY	REVISIONS
82	09/29/24	NY	REVISIONS
83	09/29/24	NY	REVISIONS
84	09/29/24	NY	REVISIONS
85	09/29/24	NY	REVISIONS
86	09/29/24	NY	REVISIONS
87	09/29/24	NY	REVISIONS
88	09/29/24	NY	REVISIONS
89	09/29/24	NY	REVISIONS
90	09/29/24	NY	REVISIONS
91	09/29/24	NY	REVISIONS
92	09/29/24	NY	REVISIONS
93	09/29/24	NY	REVISIONS
94	09/29/24	NY	REVISIONS
95	09/29/24	NY	REVISIONS
96	09/29/24	NY	REVISIONS
97	09/29/24	NY	REVISIONS
98	09/29/24	NY	REVISIONS
99	09/29/24	NY	REVISIONS
100	09/29/24	NY	REVISIONS

# EUR Wiring Diagram



## Coffee Crafters

### VALENTA 3 ROASTER WIRE DIAGRAM REV. B EUROPEAN, UK, AUSTRALIA, NZ 230 VAC, 50 HZ

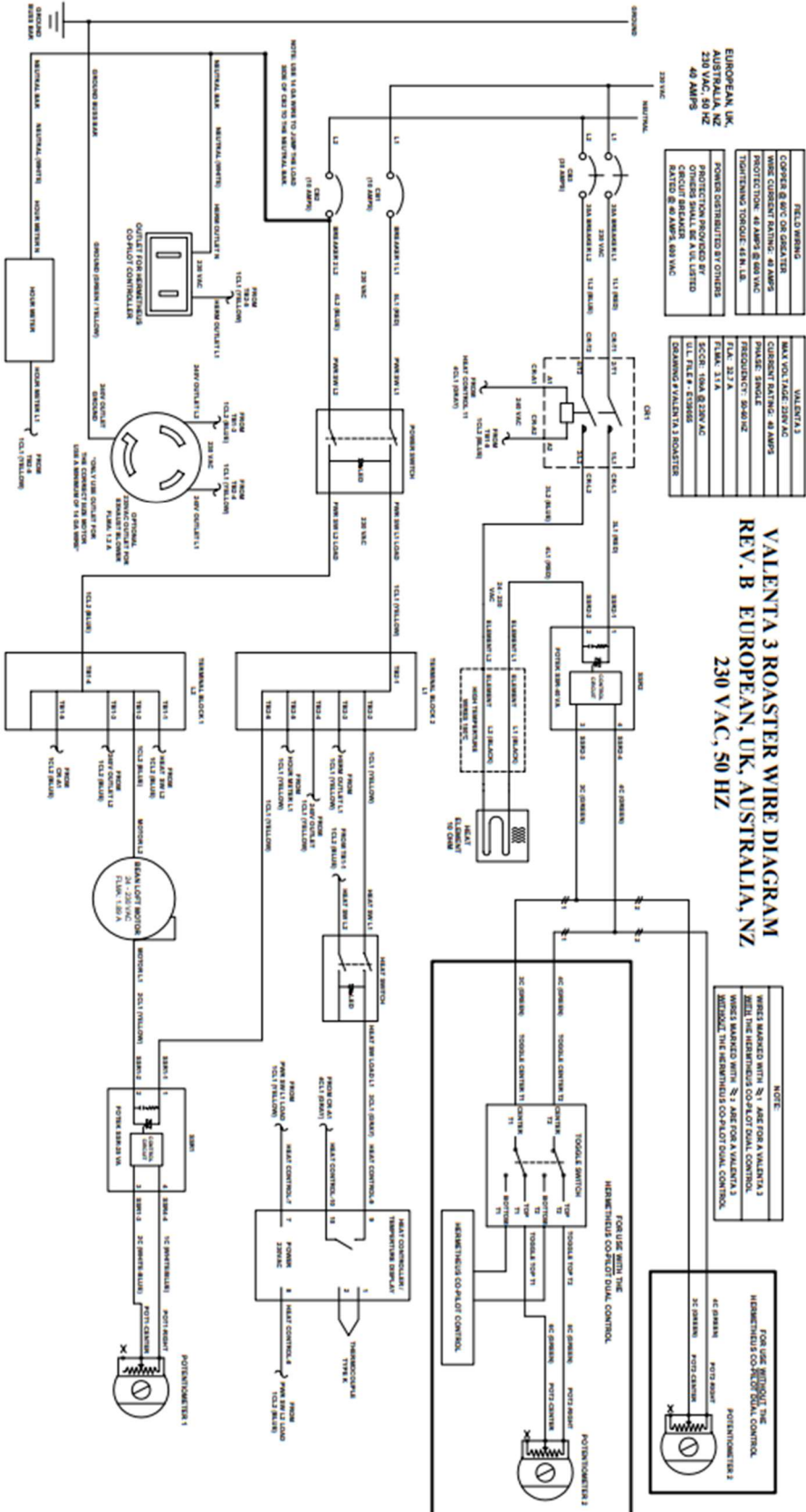

FIELD WIRING		VALENTA 3	
CORNER & BVC OR EQUIVALENT	MAX VOLTAGE: 230V AC	CURRENT RATING: 40 AMP	WIRE GAUGE: 12 AWG
WIRE CURRENT RATING: 40 AMP	PROTECTION: 40 AMP @ 230 VAC	PROTECTIVE DEVICE: 40 AMP	WIRE GAUGE: 12 AWG
PROTECTION: 40 AMP @ 230 VAC	TERMINAL BLOCK: 12 POS. 12 AWG	TERMINAL BLOCK: 12 POS. 12 AWG	TERMINAL BLOCK: 12 POS. 12 AWG
TERMINAL BLOCK: 12 POS. 12 AWG	TERMINAL BLOCK: 12 POS. 12 AWG	TERMINAL BLOCK: 12 POS. 12 AWG	TERMINAL BLOCK: 12 POS. 12 AWG
TERMINAL BLOCK: 12 POS. 12 AWG	TERMINAL BLOCK: 12 POS. 12 AWG	TERMINAL BLOCK: 12 POS. 12 AWG	TERMINAL BLOCK: 12 POS. 12 AWG

NOTE:  
WIRE #1 AND #2 ARE FOR A VALENTA 1  
WIRE #3 AND #4 ARE FOR A VALENTA 2  
WIRE #5 AND #6 ARE FOR A VALENTA 3

REV.	DESCRIPTION	DATE	APPROVED
3	WIRING IS FOR EUROPE/UK/AUS/STRALIA 230VAC, 50HZ	09/29/24	N.Y.
A	WIRING IS FOR AMERICAN 240VAC, 60HZ	09/29/24	N.Y.
	DESCRIPTION		

REV.	DESCRIPTION	DATE	APPROVED
3	WIRING IS FOR EUROPE/UK/AUS/STRALIA 230VAC, 50HZ	09/29/24	N.Y.
A	WIRING IS FOR AMERICAN 240VAC, 60HZ	09/29/24	N.Y.
	DESCRIPTION		

REV.	DESCRIPTION	DATE	APPROVED
3	WIRING IS FOR EUROPE/UK/AUS/STRALIA 230VAC, 50HZ	09/29/24	N.Y.
A	WIRING IS FOR AMERICAN 240VAC, 60HZ	09/29/24	N.Y.
	DESCRIPTION		

REV.	DESCRIPTION	DATE	APPROVED
3	WIRING IS FOR EUROPE/UK/AUS/STRALIA 230VAC, 50HZ	09/29/24	N.Y.
A	WIRING IS FOR AMERICAN 240VAC, 60HZ	09/29/24	N.Y.
	DESCRIPTION		



REV.	DESCRIPTION	DATE	APPROVED
3	WIRING IS FOR EUROPE/UK/AUS/STRALIA 230VAC, 50HZ	09/29/24	N.Y.
A	WIRING IS FOR AMERICAN 240VAC, 60HZ	09/29/24	N.Y.
	DESCRIPTION		

REV.	DESCRIPTION	DATE	APPROVED
3	WIRING IS FOR EUROPE/UK/AUS/STRALIA 230VAC, 50HZ	09/29/24	N.Y.
A	WIRING IS FOR AMERICAN 240VAC, 60HZ	09/29/24	N.Y.
	DESCRIPTION		

REV.	DESCRIPTION	DATE	APPROVED
3	WIRING IS FOR EUROPE/UK/AUS/STRALIA 230VAC, 50HZ	09/29/24	N.Y.
A	WIRING IS FOR AMERICAN 240VAC, 60HZ	09/29/24	N.Y.
	DESCRIPTION		

# Part List

Part Name	Part Number
200 Micron Chaff Bags	21BZZM NMO200P1S
400 Micron Chaff Bags	21BZYS NMO400P1S
Bean Temperature Probe (21")	WRN-535-1000
Digital Thermometer	SK-86460-03
Door Gasket	V3-RCA-112
Double Potentiometer (heat)	R-VA2XXL 500K
Fotek SSR-25	SSR 25-VA 1/4 watt
Fotek SSR-40	SSR-40VA
Heat Element	CC-HCART Mini
Loading Chute	V7-LC-1000
Loft Motor	116310-01 blower A2
Loft Motor Brushes	70989917/833508-50
Noark Contactor	EX9CK30B20
Roast Air Temp. Probe	WRN-535-1200
Roast Chamber Mount Gasket	V3-RCA-1040
Roaster Light	JT1MCJSGP pinyuan_JC8001
Sight Glass Bezel	PA6-GF
Single Potentiometer (loft)	023-638
Starter Capacitor	#24-3 capacitor chansen
Switch x2	KCD4 30A
Temperature Controller	TCS-4020
Thermometer	SK-86460-03
Thermometer Bracket	A9-HTM-1000
Thermometer Bracket Base	V7-TMB-1000
Wye Duct	ACy444



