



Coffee Crafters



Valenta 8

8-lb. Fluid Bed Commercial Coffee Roaster Manual

708 S. Clearwater Loop Ste 105

Post Falls, ID 83854

www.coffeecrafters.com

Phone (509)228-6916

info@coffeecrafters.com

Copyright © 2024 Coffee Crafters LLC All Rights Reserved

Contents

Introduction.....	4
About Us.....	4
Our Mission.....	4
Our Vision.....	4
Valenta 8 Model Complete Roasting & Bean Cooling System Specifications.....	5
Warranty And Guarantee.....	6
Valenta 8 Model Warranty.....	6
What Is Not Covered by The Warranty.....	6
Assembly And Installation.....	8
Assembly Introduction.....	8
Hardware Packages.....	8
Taking Roaster Off the Pallet.....	10
Installing Hood.....	11
Thermometer.....	12
Mounting the Thermometer Bracket to Roaster.....	13
Attaching Probe.....	14
Attaching Loading Chute.....	15
Installing Power Cord.....	16
Installing Exhaust Blower.....	17-18
Installing Ducting.....	19
Installing Ventilation.....	20
Temperature Switch.....	22
Helpful Tips.....	23
Roasting.....	24
Roast Coffee In 7 Easy Steps.....	24
Check Chaff Bag.....	24
Turn On Exhaust Blower.....	24
Turn On System Power Switch.....	25
Set Bean Loft.....	26
Load Beans in Top Green Bean Hopper.....	27
Turn on Heating Element.....	28
Roasting Complete: Cool the Beans.....	29-30

Coffee Bean Education	31
Proper Storage of Green Coffee Beans	31
Green Coffee Bean Abbreviations and Meanings.....	32
Maintenance And Troubleshooting.....	33
Maintenance.....	33
Chaff Bags	33
Roast Hopper Cleaning	33
Bean Cooling Tray	33
Mast Tubing	34
Exhaust Tubing	35
Exterior Surfaces.....	35
Troubleshooting	36-39
Exhaust Blower Losing Suction.....	36
Bean Loft Motor Won't Run	37
Both Heat Elements Won't Turn On.....	38
Bean Loft Motor Runs at Full Speed Only.....	38
Both Elements Running but Roasts Take Too Long	39
Air Coming Out of Dump Gate	39
Troubleshooting Figure 1.1	40
Troubleshooting Figure 1.3	41
Troubleshooting Figure 1.4 – SSR Connections	42
Troubleshooting Figure 1.5 – Contactors	43
Wiring Diagram USA	44
Wiring Diagram EUR	45
Part List	46

Introduction

In this manual, you will find everything needed to start roasting coffee. Included in this copy is a description of your warranty/guarantee, detailed information on installation and assembly, roasting instructions, additional information on green beans, and a troubleshooting guide.

About Us

While living in Thailand and unable to find fresh roasted coffee, Ken Lathrop, developer of Coffee Crafter's Valenta 8 coffee roaster, conceived of a concept to design and build a reliable, affordable machine capable of roasting five pounds or more of coffee beans in less than ten minutes.

"My goal was to enable new roasters – to help them roast their own beans and have fun doing it", says Lathrop. "My focus was to design and build a roaster that could be easy for anyone to learn and use, a roaster that could roast five pounds or more per roast batch and was easily installed and affordable for anyone. From the response we have received from customers and at coffee shows I think we succeeded."

Coffee Crafters designed and began selling its Artisan V fluid bed coffee roaster in August 2013. "We built the Artisan roaster specifically to serve small roasters or those new to the industry", says Lathrop. "The installation is similar to your home clothes dryer – very simple and straightforward. After installation we find that our customers are up to speed and roasting typically within 30 minutes."

Our Mission

To become the best and largest supplier of high-quality affordable coffee "micro-roasting" equipment in the world.

"Micro-Roasting" defined:

1. Hands on craft roasted coffee
2. Roasting 100 lbs. or less per day
3. Supply "fresh" coffee to Customers immediately after roasting at its peak of freshness

Our Vision

We will maintain an uncompromising commitment to our "micro-roasting" customers by:

- Serving our customers the way we would like to be taken care of.
- Providing our customers with equipment, supplies and information to satisfy all of their micro-roasting needs.
- Supplying high quality products engineered and manufactured in the USA.
- Delivering affordable factory direct equipment.



Valenta 8 Coffee Roaster

Energy Efficient Fluid Bed
Coffee Roasting System

Valenta 8 Complete Roasting & Bean Cooling System Specifications

Roaster Production	45-48 lbs. per hour
Roast Time	8-12 minutes (manually adjustable)
Chaff Collection	Stand-alone chaff canister filter system
Bean Cooling	External 8 lbs. capacity
Roast Air Temperature	Variable manual control Fahrenheit or Celsius
Bean Temperature Thermometer	Included
Roaster Power	50-amp @ 240V Single-phase (US) 60-amp @ 220v Single-phase (EUR/INTL)
Exhaust System Power	7.5-amp, 115V 60 Hz single phase
Roaster Heat	8,600 watts
Batch Size	200g to 8lbs
Venting	Intake: 4" metal ducting (provided) Discharge: 5" metal ducting (not included)
Minimum Floor Space for full system	7' wide by 3' deep

Dimensions & Weight

Roaster	71" tall x 19" deep x 60" wide
Exhaust Blower 1550 CFM	16.25" wide x 19" deep x 19.75" tall
Shipping Weight	350 lbs.
Shipping Dimensions	1 Pallet (40x48x68 inches)

Electricity Usage

Full 8 lb. load	0.4 kWh per pound
200-gram load	1.0 kWh per pound

Certification

UL

CE

Coffee Crafters
708 S Clearwater Loop, Suite 105, Post Falls, ID 83854
(509)228-6916 – sales@coffeecrafters.com

Warranty and Guarantee

Valenta 8 Model Warranty

Your Valenta 8 Roaster has been manufactured and tested to the highest quality standards by Coffee Crafters. This Limited Warranty covers defects in material or workmanship on new Valenta roasters. The Warranty extends to the original purchaser only and is non-transferable. Only consumers purchasing roasters from Coffee Crafters may obtain coverage under our limited warranty.

Coffee Crafters warrants this product against defects in material or workmanship as follows:

- Under normal installation per Coffee Crafters instructions, use, service, and maintenance for a period of one year from the original purchase date, Coffee Crafters will replace at no charge, any product or part of the product that proves defective because of improper workmanship and/or material.

The specific warranties expressed are the ONLY warranties provided by the manufacturer. These warranties give you specific legal rights, and you may also have other rights which vary from state to state.

What is Not Covered by the Warranty

1. Conditions and damages resulting from any of the following:
 - a. Improper installation, delivery, or maintenance.
 - b. Any repair, modification, alteration, or adjustment not authorized by the manufacturer.
 - c. Misuse, abuse, accidents, unreasonable use, or acts of God.
 - d. Incorrect electric current, voltage.
 - e. Improper setting of any control.
 - f. Use of risers (pedestals) that are not authorized by the manufacturer.
 - g. The Warranty is void if a product is returned with removed, damaged, or tampered labels or equipment, or any alterations.
2. The Warranty is void if the original serial numbers have been removed, altered, or cannot be readily determined.
3. Chaff Filters.
4. Products purchased for use other than roasting coffee.
5. Any food loss due to product failures.
6. Expenses for travel and transportation for product service.
7. Consequential or incidental damages sustained by any person as a result of any breach of these warranties. Some states do not allow the exclusion or limitation of consequential or incidental damages, so the above exclusion may not apply.

If You Need Service

1. See the Maintenance/Troubleshooting section of this manual.
2. Visit our YouTube channel to find Maintenance and Troubleshooting videos for tips on fixing/replacing roaster parts
3. If you are still having issues with the roaster, give us a call or send us an email so we can figure out the problem with you.
 - Phone: 509-228-6916
 - Email: info@coffeecrafters.com

30-Day Complete Satisfaction & Money-Back Guarantee

We want you to be fully satisfied with every item that you purchase from Coffee Crafters. If you are not satisfied with an item that you have purchased, you may return the item within 30 days of purchase date for a full refund of the purchase price, minus the shipping, handling, or other additional charges.

Return Instructions

Please note: For purposes of tracking and insurance, all returns must be shipped to Coffee Crafters.

1. Pack the item securely in the original package, if possible. Enclose the return portion of the original packing slip with the item.
2. All products must be returned in excellent condition, in original boxes, and with all paperwork, parts and accessories to ensure full credit.
3. All return shipping charges must be prepaid. We cannot accept C.O.D. deliveries.
4. Keep the Return Tracking Number from the package you are returning to ensure that the package is returned to the warehouse.
5. You can expect a refund in the same form of payment originally used for purchase usually within 10-15 business days of our receiving your returned product. Returned funds may reflect charges for incomplete components or damage materials. Delays may be experienced in the case of incomplete returns. Please note that your shipping costs will not be refunded.

Receipt of Damaged or Defective Items

If you receive a damaged or defective item, contact Coffee Crafters Customer Service Department at 1-509-228-6916 immediately upon receiving the item. Please supply your order number, item number and tracking number from your original confirmation e-mail. Coffee Crafters will also need your e-mail address and phone number.

A defective item may be repaired or replaced within 30 days of purchase under Coffee Crafters Warranty.

Assembly and Installation

Assembly Introduction

Your Valenta 8 roaster comes mostly assembled. The following instructions will help you complete the assembly process correctly.

Before you start the assembly process you must select a suitable location for the Roaster and Blower System. The Blower System can be installed in any location within 10 feet of the Roaster including on the other side of a wall. You may prefer this installation method if the noise is an issue. The customer must supply the 5" rigid ducting for outside venting. If you decide to put the Blower System in a different location additional vent pipe and fittings will be required. Make sure to check with local codes for venting requirements as noted in the ventilation installation section of this manual. When correctly installed, the exhaust gas temperature will not exceed 170° Fahrenheit.

The Roaster must be positioned on a flat smooth surface, do not install on carpet. Make sure the Roaster has at least a 6-inch gap between the back vent pipes and the wall.

Hardware Packages

Your Valenta 8 roaster comes with all the fittings and hardware needed to install the chaff collector, roaster, bean cooler and exhaust blower. Not included is the electrical cord or ducting on the discharge side of the exhaust blower. A complete list of included hardware and fittings and listed below.

Please Note: ALL HARDWARE is labelled by part and located in the bean cooler tray in bags.

1. Valenta 8 Hood
 - a. (4) 8/32 stainless screws
2. Thermometer Bracket
 - a. (2) 8/32 black screws
 - b. (1) 8/32 stainless screw

ASSEMBLING YOUR VALENTA 8 ROASTER



Taking the Roaster Off of the Pallet

Step 1: Unscrew the Shipping Brackets on the front and Stabilizing Feet on the back of the roaster. Set the Stabilizing Feet aside, you will be putting them back on later. You can throw out the Shipping Brackets, they are no longer needed.

Step 2: Take the roaster off of the pallet and place it in your roasting area.

Step 3: Screw the Stabilizing Feet back into the back of the roaster as pictured below. Please note: these feet are very strong and can dent the roaster if you move it while the feet are attached so it is a good idea to wait to put the feet back on until after the roaster is in the position you want to leave it in.

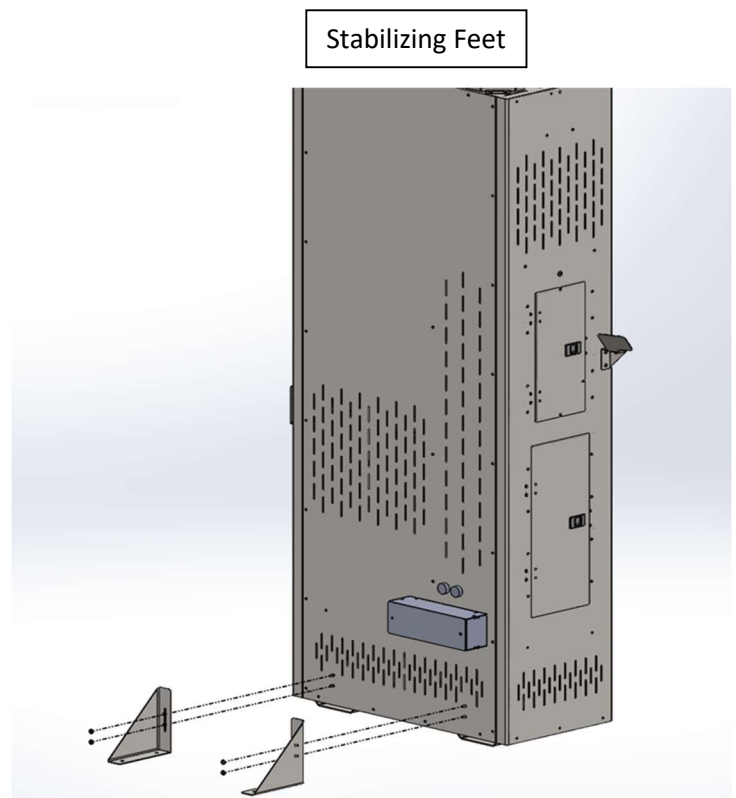
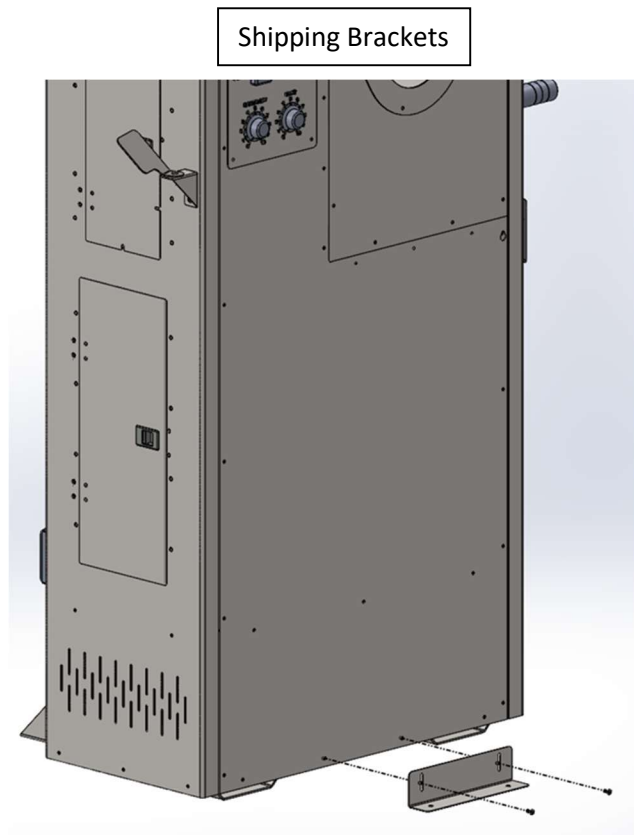

VALENTA 8 HOOD INSTALLATION

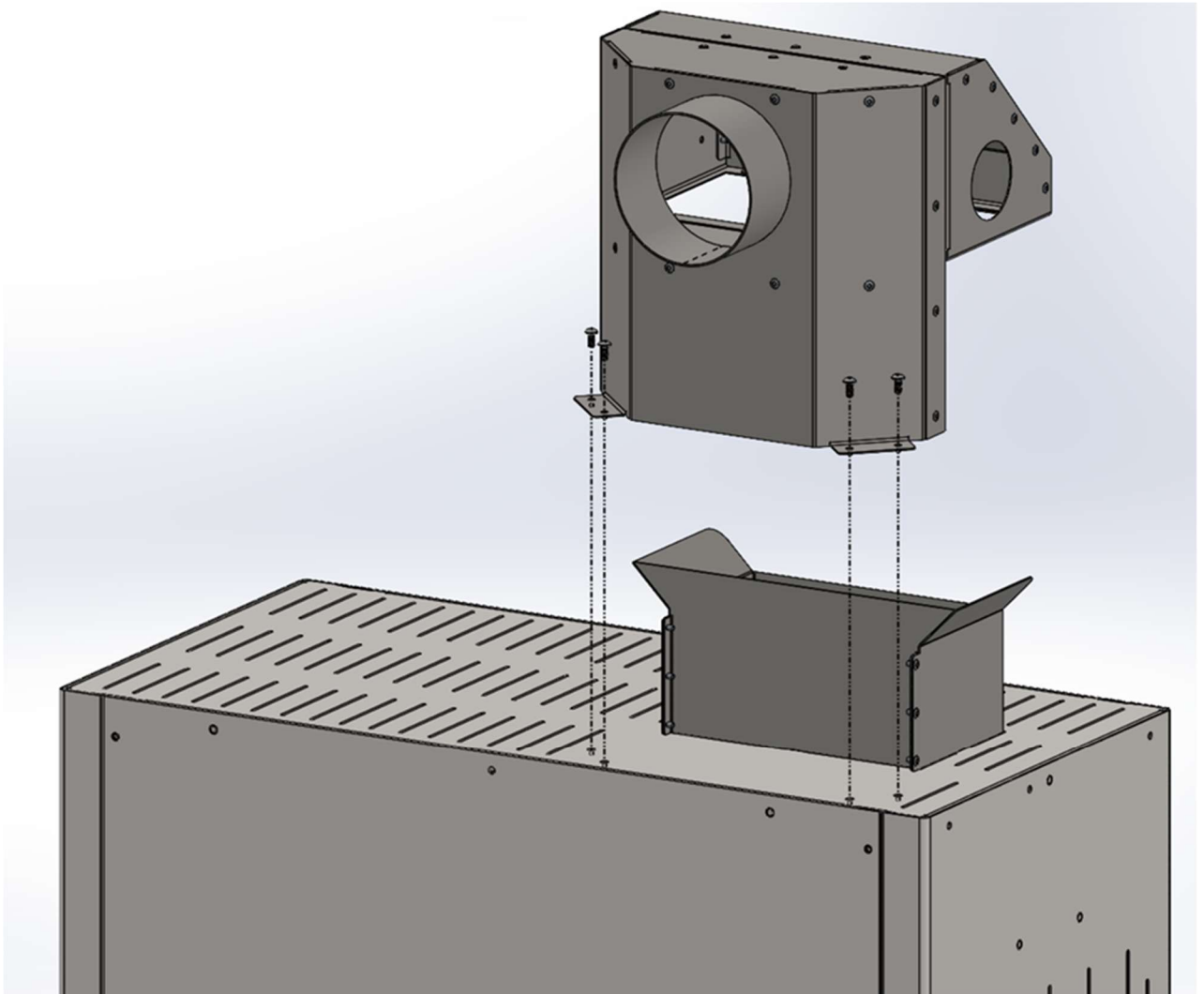

Slide the hood over the square hole on the top of the roaster. Secure the hood with 4 – 8/32 screws and tighten down.

Thermometer

Your thermometer will be placed on the Thermometer bracket located on the left side of the roaster.

The Digi-Sense Thermometer is very easy to operate (pictured). The large display makes the bean temperature reading easy to see. There are only a few basic operating functions.

1. The meter has an auto off function and will power down after 30 minutes with no key operation. To disable the auto power off mode, press and hold the "H" and "Power" keys at the same time. The clock dial in the upper left corner of the screen will disappear and the auto off will be disabled.
2. When the battery voltage is under the proper operation requirements the low battery symbol will show on the LCD screen and the battery will need to be replaced.



The thermometer comes to you with the battery and thermocouple probe installed and tested. Velcro has been applied to the back of the thermometer. To install it on the thermometer bracket, remove the plastic from the Velcro and install it on the bracket as shown in the picture below. The bottom of the thermometer should be even with the bottom of the thermometer bracket.

Mounting the Thermometer Bracket to Roaster

Step 1: Attach bracket base to the two the protruding studs on the left side of the roaster. Tighten with two 8/32 screws. Use another 8/32 screw to attach bracket to the base.



Close Up View

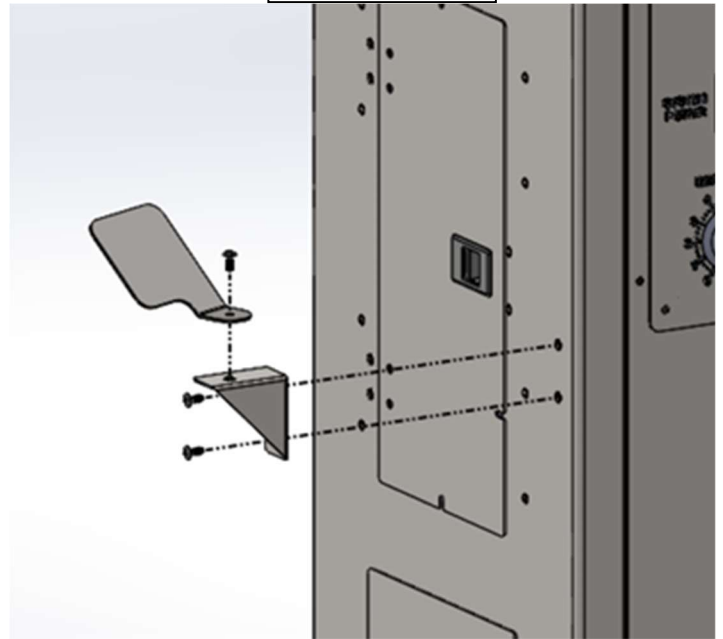

Step 2: Peel the sticker off the back of the thermometer Velcro strips.



Step 3: Secure thermometer to thermometer bracket as shown and press firmly.



Attaching the Thermocouple Probe

Step 1: Bring wire behind thermometer and plug into bottom of thermometer being careful to insert it into the correct slots.



Attaching the Loading Chute

Lift the mast up to reveal the loading area on top of the roaster. Place the loading chute over the hole in the top of the roaster as pictured below, with the rivet side facing the back of the roaster.

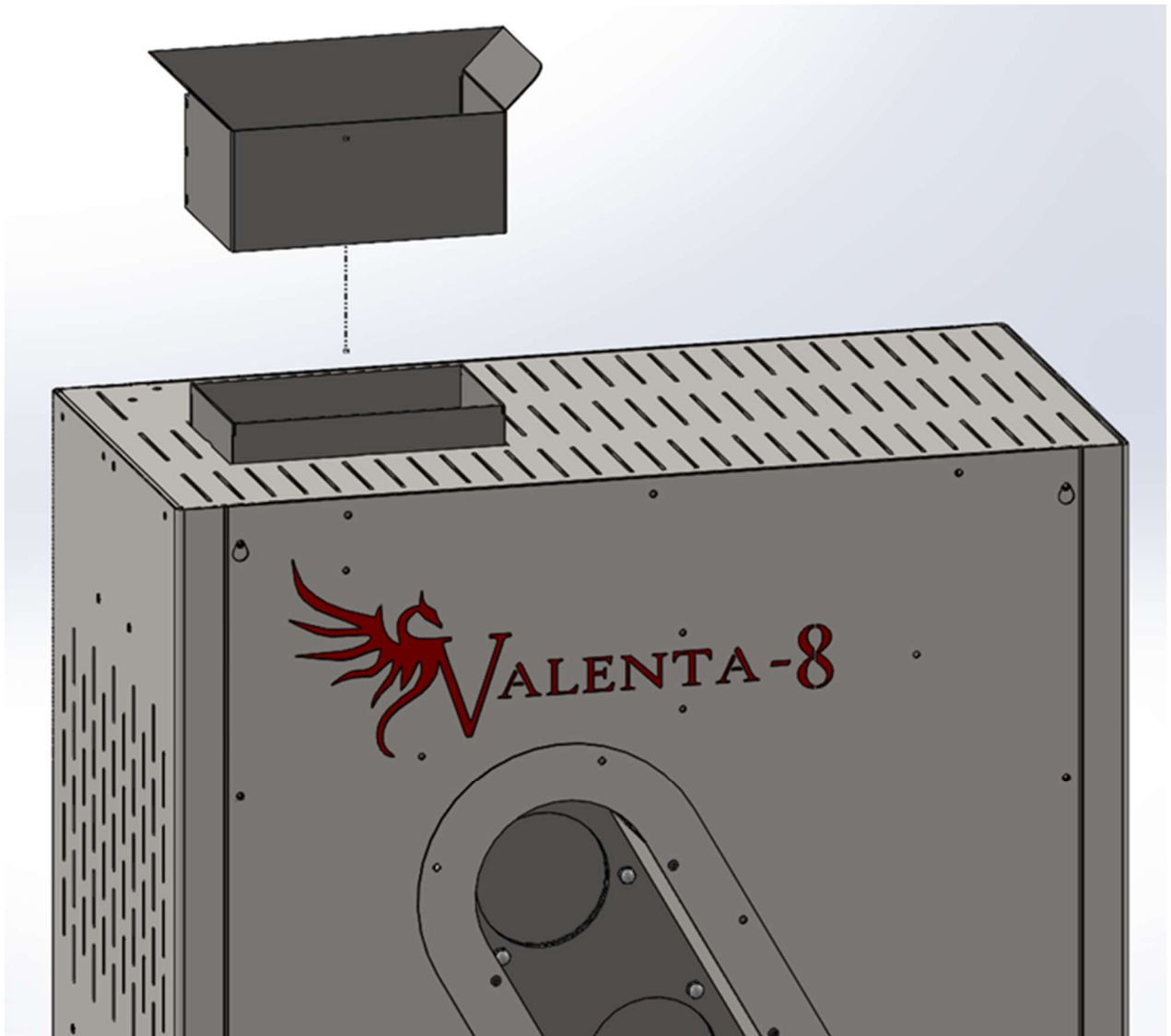

INSTALLING CONDUIT AND CORD ROUTING

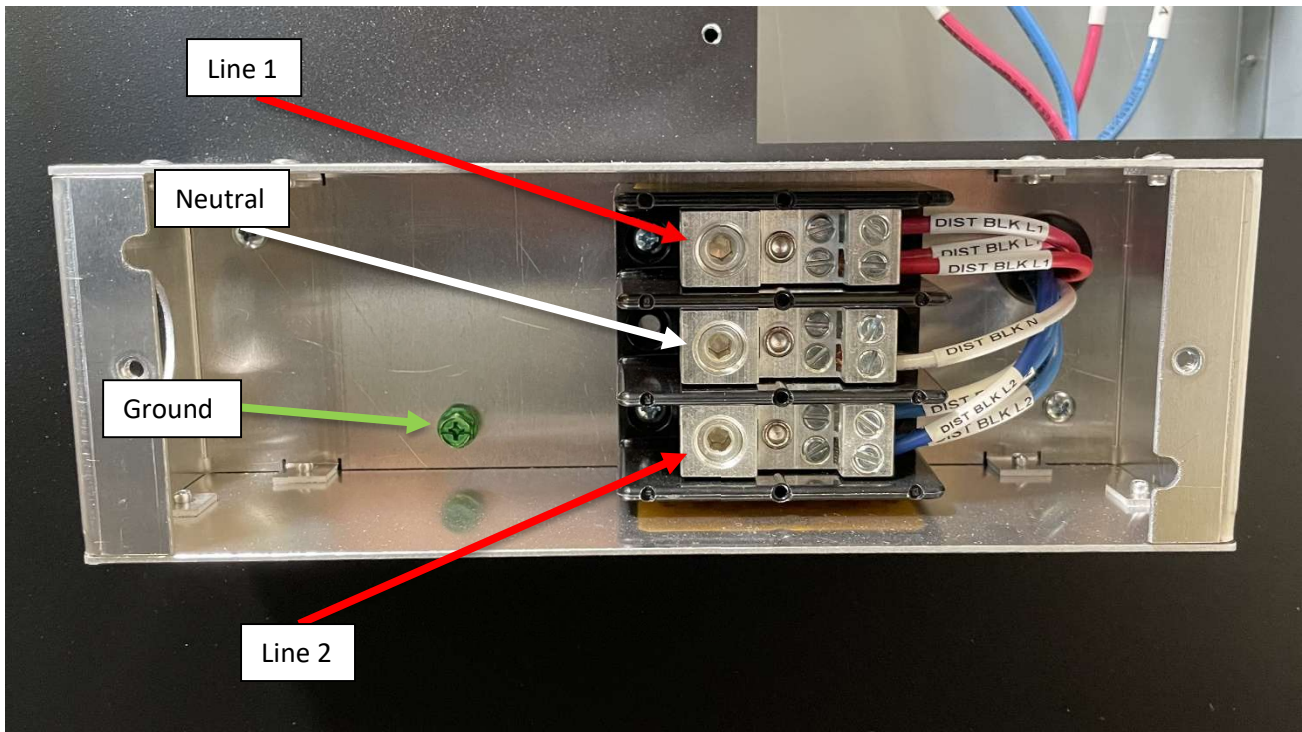

1. Install the electrical cord or rigid conduit to the power distribution block on the back of the roaster. For rigid conduit connection remove the cord grip and install the proper conduit connector.

Note: We recommend installing a pigtail and plug to ease in moving the roaster for cleaning.

INSTALLING EXHAUST BLOWER

1. You may need to power this blower separately from the roaster.
2. Place the 4 X 4 X 4 Wye on the intake side of the blower. Position it to best suit your roaster exhaust hose positions. Secure the wye with the self-taping screw provided you (attached to the wye in a plastic bag).
3. The exhaust blower comes with a 5-inch flange on the top discharge outlet. While both 4" and 5" duct is acceptable for exhaust duct size, we recommend using rigid or semi-rigid ducting to vent the roaster. Be sure to tape the duct seams on the room interior side of the duct system as discharge gas is under pressure.
4. We recommend your ducting run be no longer than 25 feet from the blower to the outside port. Be sure to use only rigid or semi-rigid ducting to increase the air velocity to the discharge point.
5. **VERY IMPORTANT! All of the duct joints and seams on the discharge side of the blower must be sealed with high temperature tape. The discharge exhaust ducts are under pressure and will leak smoke into the roasting area if not sealed.**



INSTALLING EXHAUST BLOWER CONTINUED

NOTE: Some installations may require longer runs to access a through wall fitting to the outside atmosphere. For longer runs please consult the outline below about lengths and deductions for elbows.

To reduce noise in the roasting area, install the exhaust blower under an insulated enclosure or on the other side of a wall. The exhaust blower motor is air cooled so make sure to not seal it completely without an intake air source.

Recommended Duct Length with Elbows

- 4" exhaust duct runs should not exceed 25 feet. Deduct 5 feet for every 90-degree elbow in the run.
- 5" exhaust duct runs should not exceed 20 feet. Deduct 5 feet for every 90-degree elbow in the run.

INSTALLING DUCTING

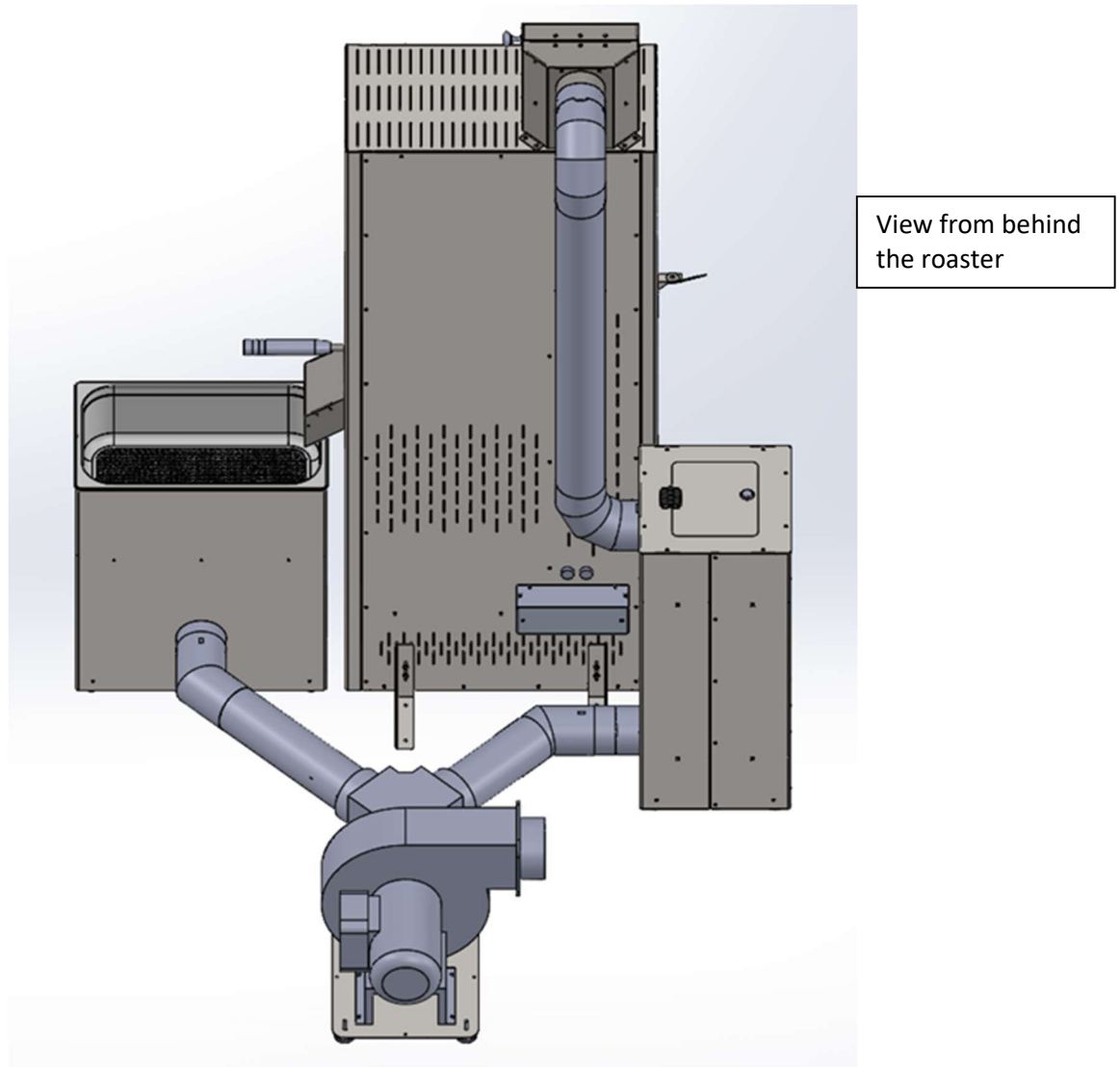

1. Use only rigid or semi-rigid ducting to vent the roaster. Arrange the ducting as shown in the diagram above.
2. All provided fittings on the roaster, chaff collector, and bean cooler are 4 inches.

Ventilation Installation

The Valenta 8 roaster must be exhausted in accordance with the manufacturer's instructions as documented in the prior section of this manual. The roaster exhaust system must be independent of all other systems.

Exhaust Penetrations

Any wall or ceiling penetration of ducts that transfer roaster exhaust must meet the International Building Code fire-resistance rating and cannot be located within any fire-blocking* and/or draft-stopping* areas. Unless such duct work is constructed of galvanized steel or aluminum of a thickness specified in Section 603.3 of the International Building Code and the fire-resistance rating is maintained.

*Fire-blocking: Prevents movement of flame, smoke, gases through concealed spaces. Primarily addresses vertical movement.

*Draft-stopping: Prevents movement of smoke and gases through concealed spaces. Primarily addresses horizontal movement.

Cleanout

All ducting from the blower discharge to the outlet terminal must have a means for cleanout. Exhaust duct cleaning is required for all coffee roasting installations. Inspect exhaust tubing frequently. Clean or replace if excessive build up is present.

Blower Intake to Roaster Ducting

Flexible ducting is acceptable from the roaster/chaff canister to the plenum. Flex ducting must be all metal. DO NOT USE plastic dryer ducting or aluminum flex duct with plastic liner.

Blower Discharge Ducting

USE ONLY RIGID ducting from the blower discharge to the outlet terminal.

Exhaust Gas Temperature

The exhaust gas temperature must not exceed 170° Fahrenheit (76.6° Celsius).

Light Kit Installation

Take your light kit out of the box and remove the plastic sheath. Place the magnetic base on the left side of the roaster and direct the light beam overtop the loading chute and into the roasting chamber.

Position the light as shown below for optimum brightness inside the hopper. **DO NOT** put the light into the chute, this will cause the light to melt!



Temperature Switch

The information contained here originated from the manufacturer, LOVE.

Bulletin E-90-TCS



Series TCS Thermocouple Switch

Specifications - Installation and Operating Instructions

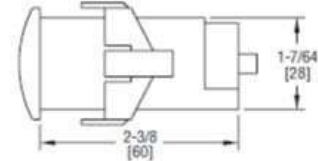
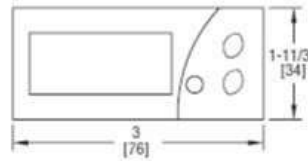

Monitor and control temperature in heating and cooling applications with the Series TCS Thermocouple Switch. The Series TCS offers a wide temperature range, two selectable alarm sets, and an internal buzzer indicating alarm condition or error. The user can define set point, heating/cooling regulation, cycle time, alarm configuration, load status, and ambient probe adjustment. The thermocouple switch features password protection and error/alarm messaging. Temperature and output status is indicated on the bright red LED display. Use the configuration key (sold separately) to quickly program multiple units. The Series TCS includes a fitting clip for panel mounting, gasket, rear terminal cover and instruction manual.

INSTALLATION

Note: Unit must be mounted away from vibration, impacts, water and corrosive gases.

- Cut hole in panel 2.80 x 1.14 inches (71 x 29 mm).
- Apply silicone (or rubber gasket) around the perimeter of the hole to prevent leakage.
- Insert unit into hole of panel.
- Slide removable fitting clips onto unit from the back until secure to panel.
- Remove back cover to wire unit.
- Wiring diagram is displayed on the top of the unit.
- (Note: PROBE CABLE LENGTH MUST NOT EXCEED 238 ft (100 m). DO NOT INSTALL PROBE CABLE NEAR POWER CABLES).
- Replace cover once wiring is complete.

SPECIFICATIONS

Probe Range: 32 to 999°F (0 to 700°C) for Type J thermocouple; 32 to 999°F (0 to 999°C) for Type K or S thermocouples.

Input: Type J, K or S thermocouple.

Output: SPDT relay rated 16A @ 240 VAC resistive.

Horsepower Rating (HP): 1 HP.

Control Type: ON/OFF.

Power Requirements: 115 VAC, 230 VAC, 12 VAC/VDC or 24 VAC/VDC (depending on model).

Accuracy: ±1% FS.

Display: 3-digit, red, 1/2" (12.7 mm) digits, plus sign.

Resolution: 1°.

Memory Backup: Nonvolatile memory.

Temperature Limits:

Ambient: 32 to 158°F (0 to 70°C);

Storage Temperature: -4 to 176°F (-20 to 80°C).

Weight: 2.3 oz (65 g).

Front Panel Rating: IP64.

Agency Approvals: CE, cUR, UR.

WIRING DIAGRAM

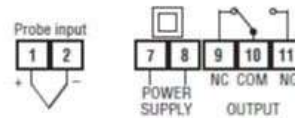

©Copyright 2014 Dwyer Instruments, Inc.

Printed in U.S.A. 2/14

FR# R0-443801-00 Rev.1

LOVE CONTROLS DIVISION
DWYER INSTRUMENTS INC.
 P.O. BOX 338 - MICHIGAN CITY, INDIANA 46360, U.S.A.

Phone: 219/879-8000 www.love-controls.com
 Fax: 219/872-9057 e-mail: love@love-controls.com

Helpful Tips

1. Go to the Maintenance and Troubleshooting section for instructions on proper cleaning of the Valenta 8 Roaster.
2. Your roaster does not require preheating.
3. Visit our website for roasting tips, the green bean distributor map, and more!



www.coffeecrafters.com

You are now ready to roast coffee. Proceed to the next section of this manual for initial testing and roasting instructions.

Roasting

Before roasting your first batch of coffee it's important to orient yourself with proper safety procedures. Treat your roaster the same as you would a cook top range. During the roast your roast hopper viewing ports get as hot as any pot on your stove. The air that roasts your coffee reaches temperatures over 500° degrees F.

Roast Coffee in 6 easy steps:

1. Check the Chaff bag
2. Turn on Exhaust Blower
3. Turn on System Power Switch
4. Set Bean Loft
5. Load Beans into the hopper through the hood with the bean loader
6. Turn on heating element

Step 1: Check the Chaff Bag

Ensure the chaff bag is secured in place and less than 50% full before roasting.

Step 2: Turn on Exhaust Blower

Never run your roaster without the chaff/exhaust blower running. The blower keeps the machine cool and prevents chaff, smoke, and heat from venting into your roast area.

The on/off switch is located on the front or side of the blower motor. This directs all the suction through the hood, so chaff does not escape.



Exhaust Blower switch

If this is your first roast of the day, preheat your Valenta 8 Roaster before you start roasting by turning on the loft to 3 and heat to 10 until you see the roast air temperature read 450 degrees F (usually 1 minute).

Step 3: Turn on System Power Switch

The system power switch is the single red switch to the left. As a safety feature the heat elements cannot be turned on with the system power switch in the off position.



Step 4: Set the Bean Loft

The bean loft blower knob is marked low to high. **Remember; never load the beans into the hopper until you have established the loft!** This prevents beans from being burned in the hopper (especially every roast after your first roast of the day as the heating elements will still be very hot). Slowly turn up the air by turning the knob clockwise. Practice this several times before turning on the heat to familiarize yourself with the feel of lofting beans.

Set the bean loft according to the recommended setting on page 28. Please note: You will set the loft at a slightly higher setting while loading the beans and then turn it down slightly while roasting. This is a safety precaution because the beans will burn very quickly if they are not moving the entire time they are in the hopper. Once the beans are in the hopper, you will turn down the loft slightly so the beans can settle into their roasting cycle.

CAUTION:

Never let the beans stop lofting with the heat elements on. You will burn your beans and possibly damage your Roaster.

Airflow simulation →

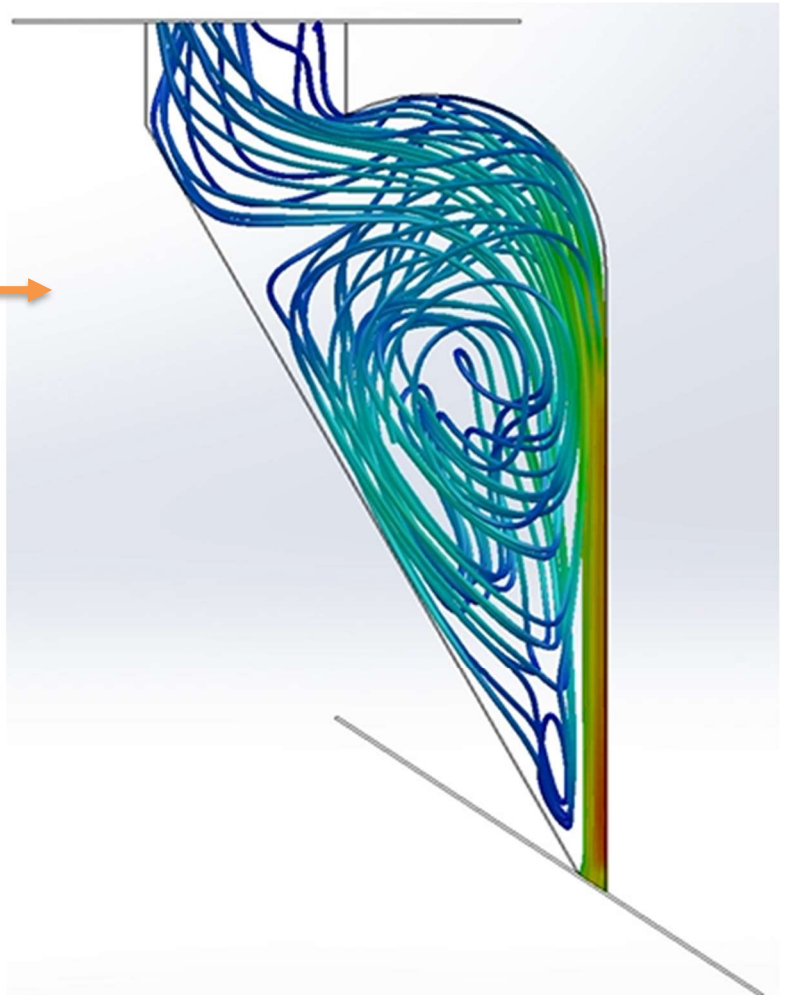

Step 5: Load Beans in Top Hopper

Make sure your air loft adjustment is on prior to pouring in the beans.

Load the beans into bean hopper by moving the hood up and pouring the beans down the loading chute. We recommend food grade bucket for the pouring process that will hold 8 lbs. of green beans.



Step 6: Turn on Heating Element

1. Turn on the heating elements switch.
2. Use the heat adjustment knob (measured from 1 to 10) below the Temperature Controller to set the heat for your batch size.
3. Re-adjust your bean loft if needed-sometimes the loft decreases after the heat switch is turned on.

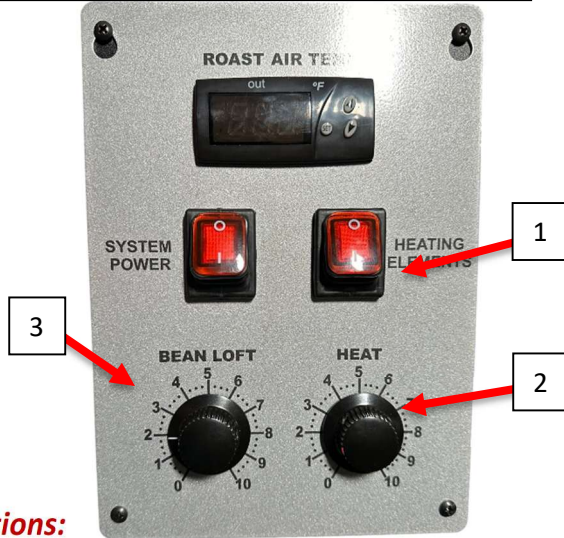

Roasting Recommendations:

BATCH SIZE IN LBS	Loading Loft	Roasting Loft	HEAT SETTING
1	3	2.75	5
2	3	3	5.5
3	3.5	3	5.5
4	3.5	3.5	6
5	6.5	4	6.5
6	5	4	7
7	5.5	4.5	7.5
8	8	4.75	10

NOTE: These are only recommendations and may vary based on altitude, humidity, line voltage and ambient air temperature.

You can increase or decrease the heat setting to achieve the temperature you need.

Roasting times may vary due to room temperature, or if machine is warm or cold. Always monitor the batch while roasting, NEVER leave unattended and watch the bean temperature to achieve the desired roast. You will quickly learn which settings work best for your roasting style.

If roasting below a 200-grams batch, the bean temperature may not read accurately.

Roasting on the Valenta 8 is very easy. Never leave your roaster unattended. If you lose your bean loft you will ruin your batch and possibly damage your Roaster. Coffee beans will catch on fire if they stop circulating!

Roasting Complete: Cool the Beans

Coffee beans must be cooled quickly after you reach your desired bean temperature. You can see into the hopper as the roast progresses, but a good rule of thumb is to stop your roast a few degrees before you reach your desired temperature. With the light shining in the hopper, the beans look lighter than they do when removed from the hopper.

1. Open the bean cooler blast gate.
2. Turn off the Heat element switch.
3. Turn down the loft if needed.
4. Lift the dump gate and let the beans fall into the bean cooling tray.



Pull knob out for cooling. Open prior to dumping Roasted beans. Close after the cooling cycle.

With the beans in the cooling tray, stir the beans occasionally with a stainless-steel spoon to make sure no hot spots remain in the corners. As you stir your beans, this is a good time to check for any rocks or foreign objects. Cooling takes about 1 minute for smaller loads and about 2 minutes for larger loads.

After your beans are sufficiently cooled down, return the cooling knob to its original position by closing the air tube under the perforated tray. Our tray is designed to be removed for easy pouring of roasted beans.



Coffee Bean Education

Proper Storage of Green Coffee Beans

The two most important variables for storing your beans are humidity and temperature.

Your green beans will keep for over 2 years when stored properly.

Some good tips to keep in mind:

- Store beans between 50-85° F (If the temperature is comfortable for you, it's comfortable for your beans)
- If you purchased full bags, keep beans in jute bag they came in for good breathability
- Keep your beans off the ground (wood pallets work best). This helps promote all around air circulation and prevents condensation
- Keep away from pets
- Place beans away from sink and water sources

Things to avoid:

- High humidity
- Changes in temperature
- Direct sunlight

If you are purchasing smaller quantities and don't plan on storing your beans for long periods of time, storing your beans in food grade buckets will work well. These Gamma screw lids give an airtight seal and are easy to open/close (available on Amazon).



Another great, but expensive, storage option is to keep beans in vacuum sealed bags. Vacuum packed beans do not need to be monitored as much since they are not exposed to oxygen and atmospheric moisture.

Green Coffee Bean Abbreviations and Meanings

SSFC – Strictly Soft Fine Cup – Grown at relatively low altitudes (under 1200 meters). These beans mature quickly and produce a lighter, less dense bean. This term also means the beans are free of hard rioy taints. Fine cup means it is a specialty grade coffee.

RFA – Rain Forest Alliance – Meets the standards that are intended to protect the environment and the rights of workers.

FTO – Fair Trade Organic – Certified as a fair-trade bean with Organic classification.

FT – Fair Trade – Certified as a fair-trade bean.

EP – European Preparation – These beans are hand sorted to remove any defective beans and foreign material.

SHB – Strictly Hard Beans – Grown at an altitude above 1350 meters.

SWP – Swiss Water Process – Decaffeinating process that includes a “flavor charged” water. 100% chemical free.

MWP – Mountain Water Process – Decaffeinating process that results in flavorful beans that are 99.9% caffeine free.

MC – Methylene Chloride – Used to decaffeinate coffee and some believe it to maintain coffee flavor better than other processes.

EA – Ethyl Acetate – An ester found naturally in fruits and vegetables that is used to decaffeinate coffee.

SHG – Strictly High Grown – This classification is higher than HB (Hard bean).

AA – Reference to a 17/18 screen size.

AB – Refers to size. AB consists of both A and B coffee beans; screen sizes 15 and 16. AB are small than AA and not as valued.

Fancy – Refers to better quality than average specialty quality for Arabica beans.

17/18 – Refers to screen size. The larger bean size generally correlates to a higher quality bean.

Rioy Taints – Defect in the bean resulted from an over ripened cherry.

Quaker – Defect in bean. Unripe cherry.

Maintenance and Troubleshooting

Maintenance

Your Roaster requires periodic maintenance and cleaning. Maintenance and cleaning will be dependent on the amount of coffee you roast.

Chaff Bags

Every time you roast, inspect the condition of the chaff bag. The suction works best when the bag is less than half full and clean. Empty your bag often. When the bag becomes covered in excess chaff dust, replace with a clean bag. Dirty Chaff bags can be washed with a mild detergent and air dried completely to use again.

Inside the Chaff Collector unit can be vacuumed after the chaff bag is removed for cleaning.



Roast Hopper Cleaning

Please refer to our YouTube video on removing and cleaning the hopper:

Video coming soon.

Bean Cooling Tray

With use, especially with darker roasts, you will notice a buildup of oils inside your cooling tray. Remove the tray and wash with warm soapy water, rinsing and drying well. When the tray is removed from the cooling unit, take this time to clean out any beans that have fallen into the cooling void under the tray. A vacuum will remove the dust and beans then you can wipe out this area with a damp cloth.

Mast Tubing Maintenance

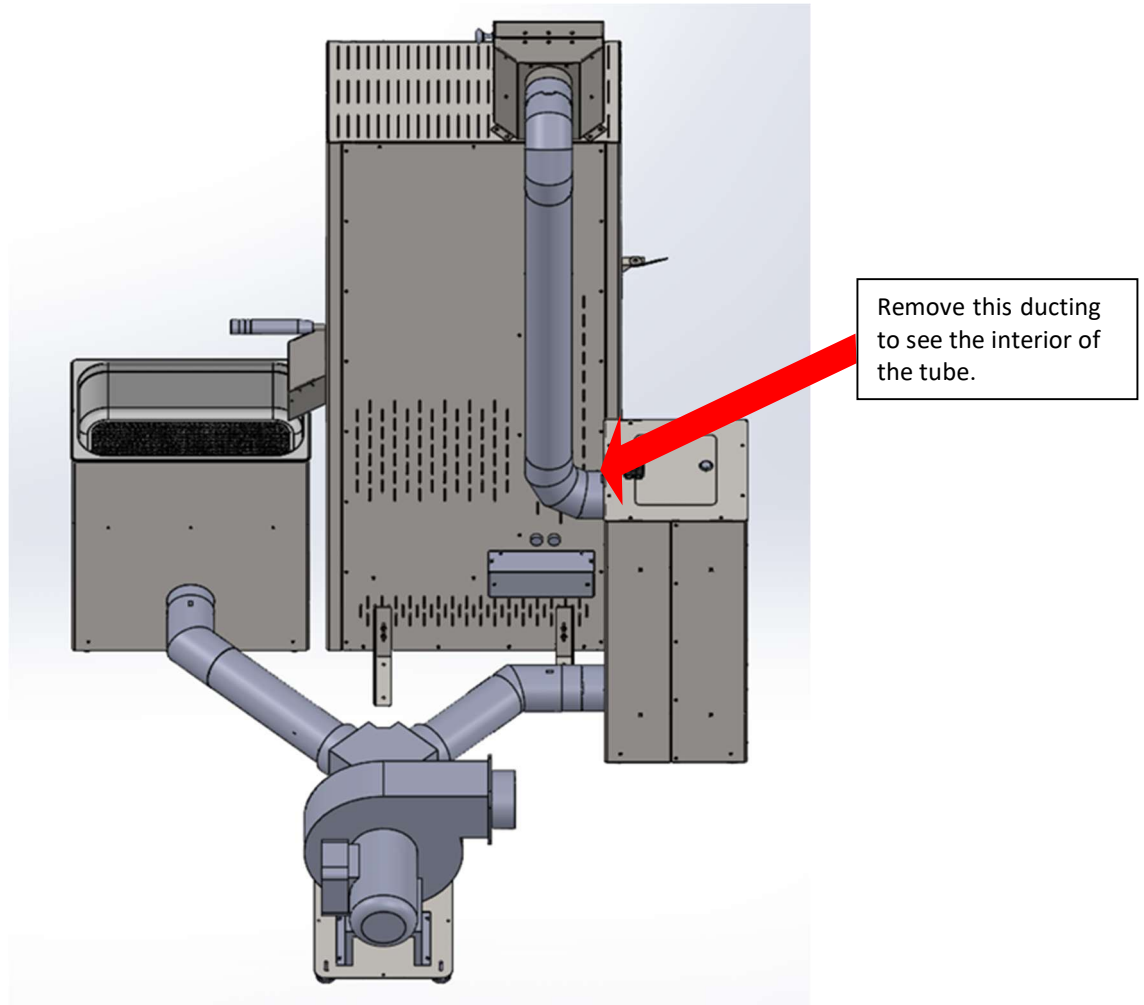

Replace or clean your ducting when dirty. This can be checked by removing the duct on the upper chaff collector as indicated in the image above. Please note, this image is used to show how the exhaust blower is hooked up to the roaster but the blower can be moved to either side of the roaster as you see fit.

Exhaust Tubing



← Rigid Tubing

← Semi-Rigid Flex Tubing

****IMPORTANT- Make sure to unplug the blower before attempting any of the following steps****

You will need to access the inside of the solid exhaust tubing to be able to run a brush down the inside of the tubing. If you have elbows in your exhaust tube line, you may have to take apart your line to fully clean the exhaust tubes.

After the solid tubing is cleaned, inspect the inside of your blower prior to reinstalling the tubing. Take a brush and go over each fin on the inside of the blower. Once everything is reattached, turning on the blower will remove the debris. (See YouTube video on blower cleaning)

Depending on how many pounds (lbs.) of beans you roast daily will determine how often you change/clean the tubing. The buildup of chaff dust can present a fire hazard. When the inside of the tubing is completely covered with dust, it is a good time to clean/replace it. (See YouTube video on venting)

Exterior Surfaces

It is sufficient to clean the lid by wiping down its surface with a damp cloth. Never use an overly wet towel to clean the lid. Any excess liquid could damage electrical components.

The body of the Roaster can be washed down with a damp cloth or mild detergent. Do not use industrial spray cleaners/degreasers on your roaster.

Troubleshooting

This portion of the manual is intended to provide guidance for roaster owners and qualified repair persons working on the Valenta 8.

Mechanical and operational issues most commonly experienced by customers are addressed. The Valenta 8 has proven to be a very reliable machine but like all mechanical devices, things will go wrong.

Coffee Crafters roasters were designed from the ground up to be very easy to operate and maintain. All wiring is color coded and labeled. Additionally, videos are available on changing most of the machine components.

Coffee Crafters maintains a full inventory of replacement parts. Please refer to the Parts List section of this manual when ordering. Your machine serial number can be found on the top of the power distribution block on the back of your machine. Please include your machine serial number when making inquiries about your machine. Coffee Crafters maintains a history of your machine accessible with your machine serial number.

Problem	Cause(s)	Solution
Exhaust blower starts to lose suction	<ol style="list-style-type: none">1. The chaff bag is dirty.2. An obstruction in the vent pipe.3. The bean cooler blast gate is open.	<ol style="list-style-type: none">1. Replace the dirty chaff bag with a clean one.2. Check the vent pipe from the blower discharge through the through wall fitting. Remove obstruction or replace damaged duct pipe.3. Close the bean cooler blast gate while roasting. <p>Note: The most common cause for a loss in exhaust suction is a dirty chaff filter bag. The bag will plug much faster with darker roasts which produces oily residue captured by the bag.</p> <p>The filter bags are machine washable. Check filter bags often and replace when dirty.</p> <p>Clean filter bags reduce exhaust temperature and keep your machine running smoothly.</p>

Problem	Cause(s)	Solution
Bean Loft motor won't start.	<ol style="list-style-type: none"> 1. System power switch is in the "off" position. 2. Faulty system power switch. 3. SSR-3 has failed. 4. Faulty potentiometer. 5. Tripped system power fuse. 	<ol style="list-style-type: none"> 1. Ensure system power switch is in the "on" position. 2. Check system power switch voltage when in the 'on' position. If no voltage, replace switch. 3. Check SSR-3 voltage output. If no voltage output, replace SSR-3. 4. Check motor speed control potentiometer for linear resistance. If ohms of resistance do not reduce to "0" when potentiometer is turned all the way up, replace potentiometer. 5. Check for tripped system power fuse located on the back of the machine. <p>Note: A tripped system power fuse is an indication that a fault has occurred in the system.</p> <p>If by resetting the fuse, it does not come on, call the manufacturer.</p>

Problem	Cause(s)	Solution
Bean Loft motor powers up but elements won't turn on.	<ol style="list-style-type: none"> 1. Heat element switch failed. 2. Faulty connector on input side of heat switch. 3. Temperature controller setting. 4. Faulty temperature controller. 	<ol style="list-style-type: none"> 1. Replace heat element switch. 2. Replace connector and heat switch. 3. Check the roast air temperature control setting. Roast air temperature must be set higher than your desired ending bean temperature. 4. Replace temperature controller. <p>Note: The system power switch supplies power to the input of the heat switches when in the "on" position. If the heat elements do not come on when the heat switch is turned "on", check the voltage on the output of the heat switch (center terminal). If no voltage, replace switch.</p>

Problem	Cause(s)	Solution
Speed control knob will not reduce bean loft motor RPM.	<ol style="list-style-type: none"> 1. SSR-3 has failed. 2. Motor speed control potentiometer has failed. 	<ol style="list-style-type: none"> 1. Replace SSR-3. 2. Replace motor speed control potentiometer.

Problem	Cause(s)	Solution
Both elements running but roasts take too long.	<ol style="list-style-type: none"> <li data-bbox="412 266 755 331">1. Ambient air temperature too low. <li data-bbox="412 369 651 401">2. Low line voltage. 	<ol style="list-style-type: none"> <li data-bbox="784 266 1419 365">1. Roast smaller loads until you identify maximum load size where machine can reach optimum roast air temperature. <li data-bbox="784 443 1195 474">2. Install a buck boost transformer. <p data-bbox="784 516 1446 615">Note: Roasting in cold environments below 50° Fahrenheit will increase roast times. We suggest roasting in an enclosed, heated environment in cold weather.</p> <p data-bbox="784 657 1430 827">The roaster does not perform well below 235-line voltage under load. If you confirm that both heat elements are running but have trouble achieving your desired roast air temperature with full loads, have a qualified electrician check your line voltage under load.</p>
Air coming out of Dump Gate.	<ol style="list-style-type: none"> <li data-bbox="412 871 662 936">1. Dump gate needs adjusting. 	<ol style="list-style-type: none"> <li data-bbox="784 871 1219 936">1. See video on adjusting Dump Gate (Insert QR code to video)

Troubleshooting Figure 1.1

Image of Roaster with the front panel removed.



Electricals with back panel removed.



Wiring connection of controllers underneath the lid.

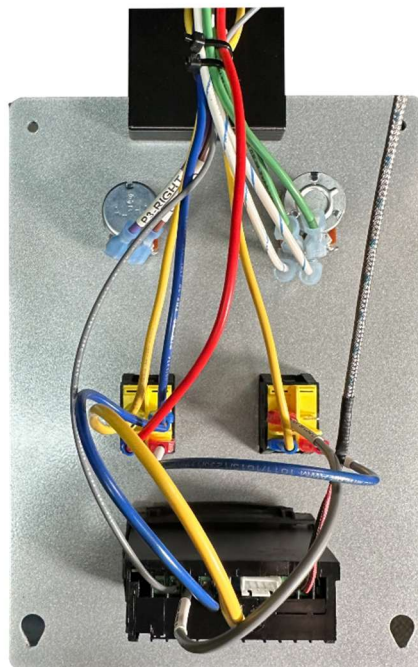

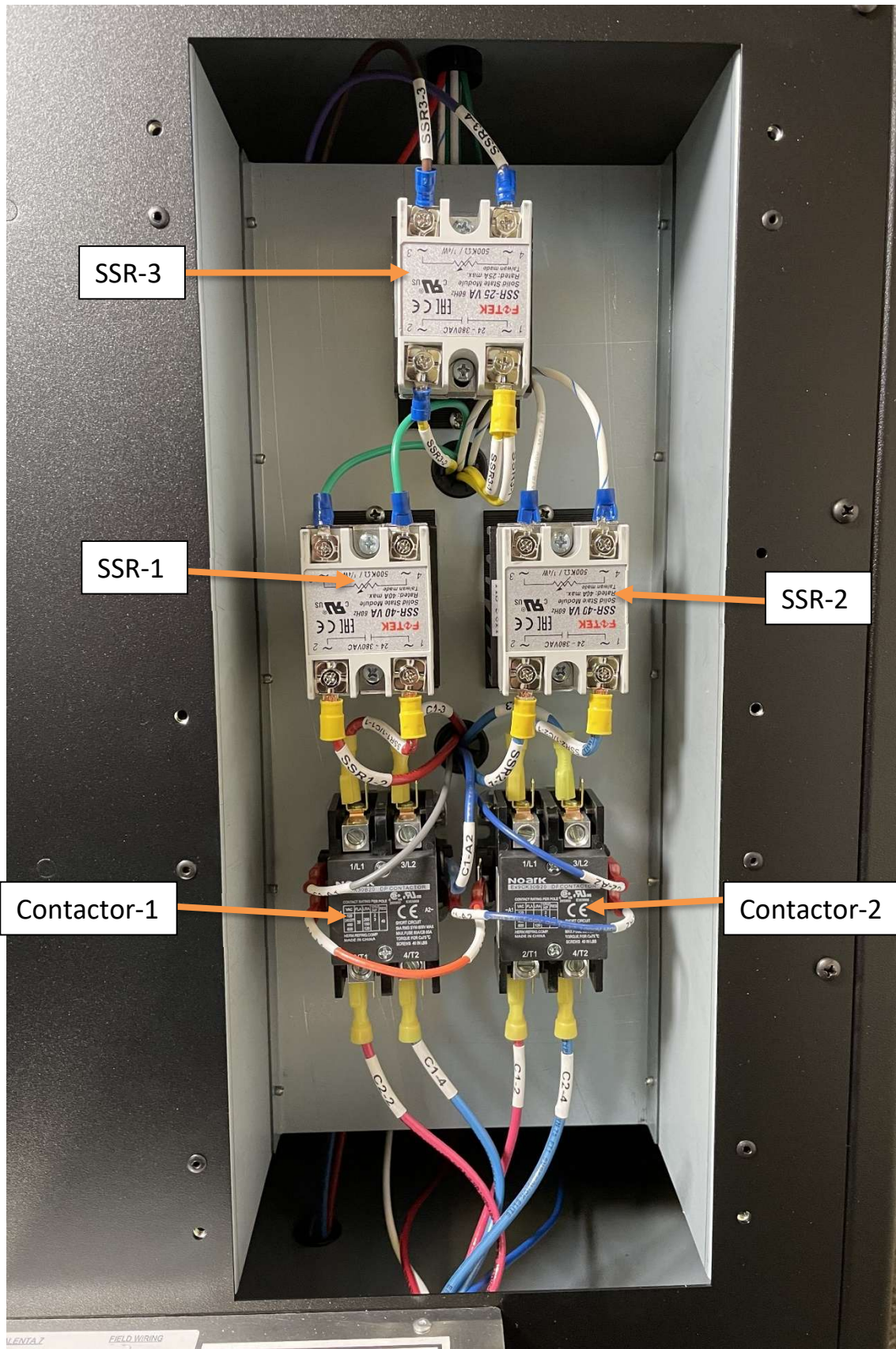

Note that the SSR's are installed with the writing upside down. Potentiometer connections are on the top, power connections are on the bottom.

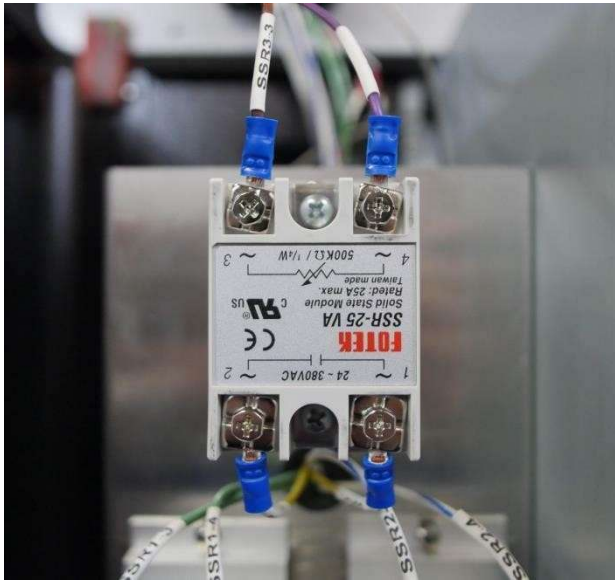

← **SSR 3**
Motor Speed Control Module



← **SSR 1 and 2**
Heat Control Modules

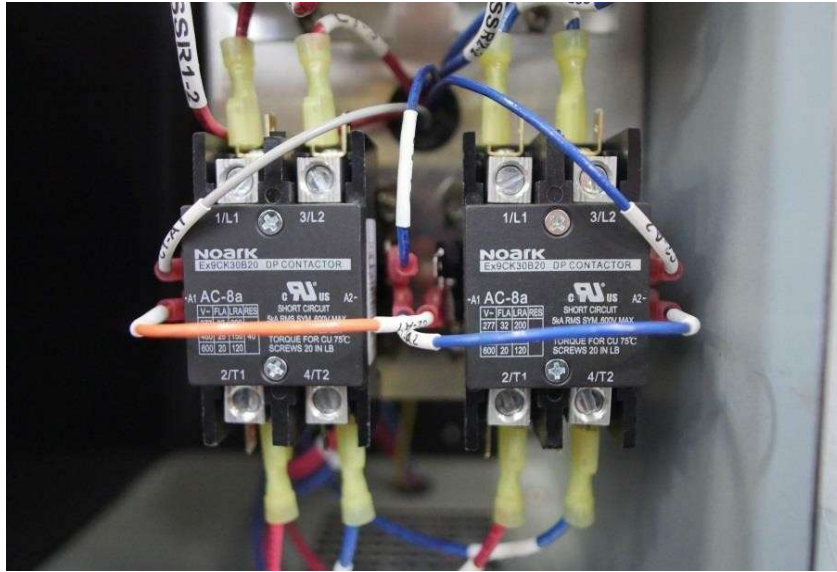

Noark Contactors

USA Wiring Diagram



Coffee Crafters

VALENTA 7/8/12 ROASTER WIRE DIAGRAM REV. A AMERICAN 240 VAC, 60 HZ

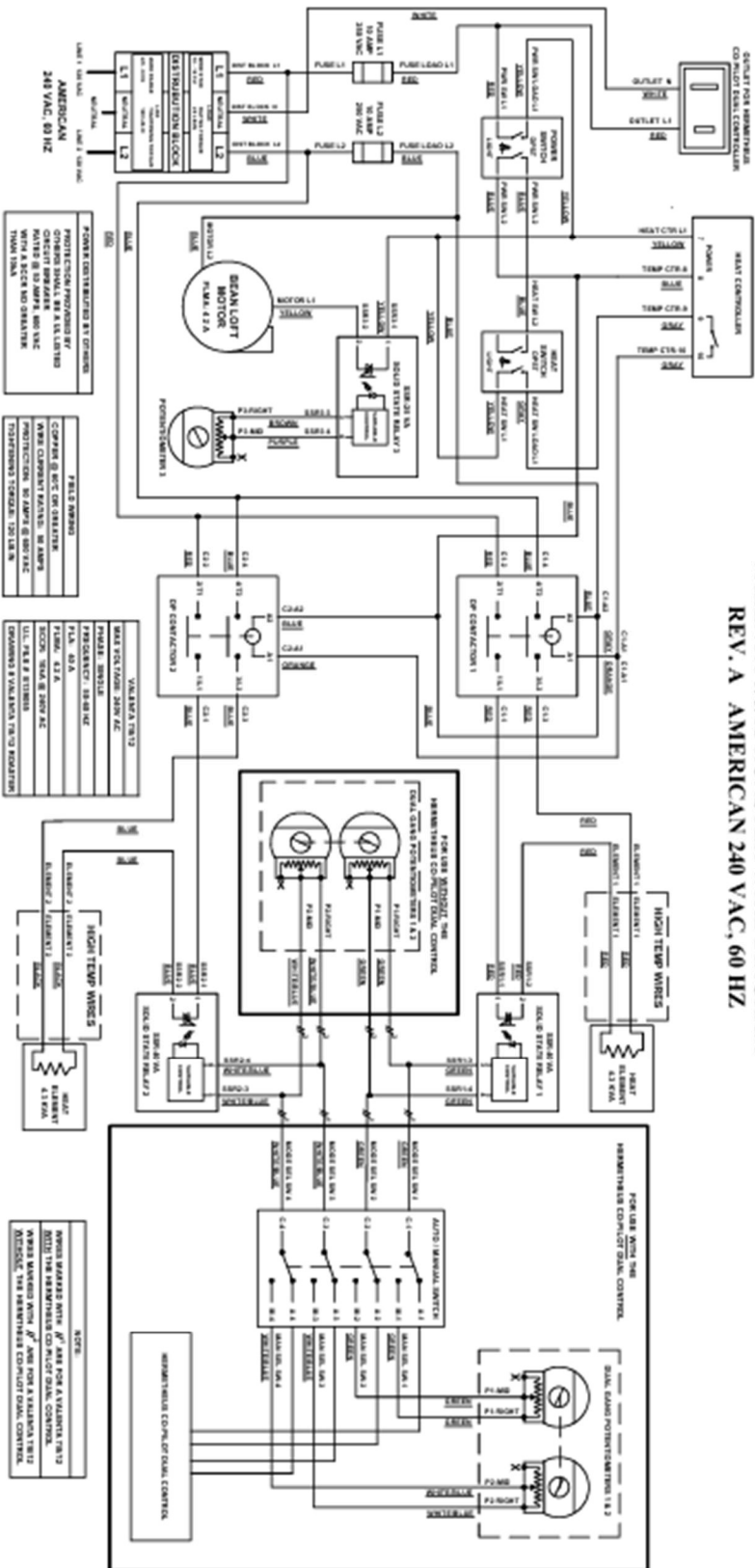

Pantrol

 800-261-2565 www.pantrol.com

FUNCTION OF CONTROL
 THIS IS THE MAIN WIRING DIAGRAM FOR THE VALENTA 7/8/12 ROASTER. IT SHOWS THE CONNECTIONS BETWEEN THE MAIN POWER SUPPLY, THE CONTROL UNITS, THE HEATERS, AND THE MOTORS. THE WIRING IS BASED ON THE AMERICAN 240 VAC, 60 HZ VERSION. THE WIRING IS SUBJECT TO CHANGE WITHOUT NOTICE.

NOVA	REV	DATE
ORDER	REV	DATE
REV	REV	DATE
SCALE	SCALE	SCALE

TITLE: COFFEE CRAFTERS
 VALENTA 7/8/12 ROASTER
 WIRE DIAGRAM

SCALE: 1" = 1"



Coffee Crafters

VALENTA 7/8/12 ROASTER WIRE DIAGRAM
 REV. B EUROPEAN, GB, AU, NZ, 230 VAC, 50 HZ

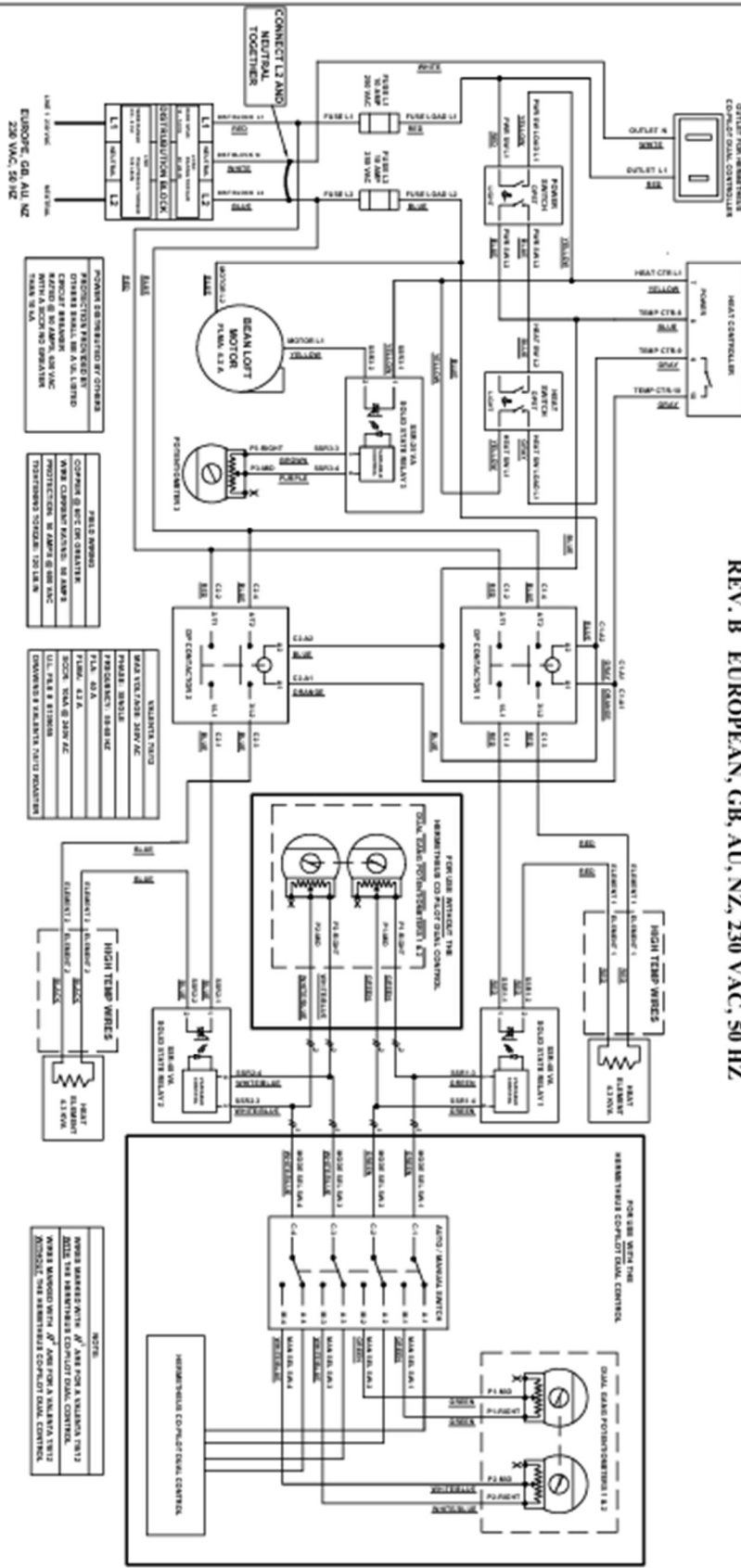

REV. B	VALENTA 7/8/12 ROASTER WIRE DIAGRAM	10/20/20	N.Y.
REV. A	VALENTA 7/8/12 ROASTER WIRE DIAGRAM	10/20/20	N.Y.
REV.	DATE	APPROVED	

800-261-2565	www.pantrol.com

TITLE: COFFEE CRAFTERS VALENTA 7/8/12 ROASTER WIRE DIAGRAM	
REV. B	DATE: 10/20/20
REV. A	DATE: 10/20/20
REV.	DATE:

Part List

Part Name	Part Number
200 Micron Chaff Bags	21BZZM NMO200P1S
400 Micron Chaff Bags	21BZYS NMO400P1S
Bean Temperature Probe (21")	WRN-535-1000
Borosilicate Glass (16GA)	V7-RCA-1131
Chansen Blower	chansen
Chansen Blower Capacitor	#24-3 capacitor chansen
Chansen Blower Switch	#29-#34 switch & cover
Digital Thermometer	SK-86460-03
Door Gasket	V7-RCA-112
Double Potentiometer (heat)	R-VA2XXL 500K
Fotek SSR-25	SSR 25-VA 1/4 watt
Fotek SSR-40	SSR-40VA
Glass Gasket	V7-RCA-1134
Heat Element	21-21852-04 (8.6kw 240v)
Loading Chute	V7-LC-1000
Loft Motor	116310-01
Loft Motor Brushes	70989917/833508-50
Motor Assembly	V7-MTR-1000
Noark Contactor	EX9CK30B20
Roast Air Temp. Probe	WRN-535-1200
Roast Chamber Mount Gasket	V7-RC-1000
Roaster Light	JT1MCJSGP pinyuan_JC8001
Single Potentiometer (loft)	023-638
Starter Capacitor	#24-3 capacitor chansen
Switch x2	KCD4 30A
Temperature Controller	TCS-4020
Thermometer	SK-86460-03
Thermometer Bracket	A9-HTM-1000
Thermometer Bracket Base	V7-TMB-1000
Wye Duct	ACy444



